

QINGDAO FLUIDO INDUSTRIAL CO.,LTD. FLANGE CATALOGUE 2019



QINGDAO FLUIDO INDUSTRIAL Co., Ltd is a leading manufacturer and exporter of various pipe fitting, flanges and cast iron valves. Its main products include:

Pipe fittings: Butt Welding Pipe Fittings, high pressure pipe fittings, stainless steel screw fittings, pipe nipples and coupling.

Flanges: Flat flanges, welding neck flanges, slip on flanges and blind flanges.

Valves: Cast iron/Ductile iron/Cast steel valves (DIN3352 Resilient seated F4/F5 Gate valves, DIN3352 F4/F5 metal seated Gate valves, BS5163/BS5150/AWWA C509 Gate valves, API600 Gate valves, Cast iron butterfly valves, DIN/ANSI Globe valves, Wafer/swing check valves and Y-strainers.

We have passed not only the European CE certification for our valves and flanges, but also the ISO9001 assessment and registration by SGS for quality management. By virtue of 20+ years' business accumulation in more than 35 countries/regions, FLUIDO has been receiving worldwide attentions. "Trust from quality", with years of industrial experience, mature quality control, stable business operation processes, and a continuously developing ideas, FLUIDO is your best partner. Welcome to contact us, and we are committed to meeting all of your needs!

Table of Contents

About FLUIDO	page1#
ASME B 16.5 Flange	page2-8#
ASME B 16.47 Flange	page9-10#
ASME B 16.48 Flange	page11#
ASME B 16.36 Flange	page12#
AWWA C207 Ring Flange	page13-16#
DIN Flange	page17-25#
AS2129/AS4087 Table Flange	page26-27#
EN1092-1 Flange	page28-38#

Flange Material:

- Carbon Steel: ASTM A105 / ASME SA105, ASTM / ASME A 350 , ASTM A181 LF2 / A516 Gr.70 A36, A694 F42, F46, F52, F60, F65, F706,ASTM A350, LF2, LF3
- Stainless Steel: ASTM A182, A 240 F304, 304L, 304H, 316, 316L, 316Ti, 310, 310S, 321, 321H, 317, 347, 347H, 904L
- Duplex & Super Duplex Steel: ASTM A182 / ASME SA182 F44,F45,F51,F53,F55,F60,F61
- Alloy Steel: ASTM A182 / ASME SA182 & A387 F1, F5, F9, F11, F12, F22, F91,ASTM SB564, SB160, SB472, SB162 Nickel 200, Nickel 201, Monel 400, Monel 500, Inconel 800, Inconel 825, Inconel 600, Inconel 625, Inconel 601, Hastelloy C276, Alloy 20
- Copper Alloy Steel: ASTM SB 61, SB62, SB151, SB152 UNS No. C 70600, C 71500

Surface treatment: Antirust oil, black / yellow / transparent / electric galvanized / hot galvanized.

Packing: Sea-worthy packing in wooden cases or pallets.

ASME B 16.5-2013 Class 150 Flange

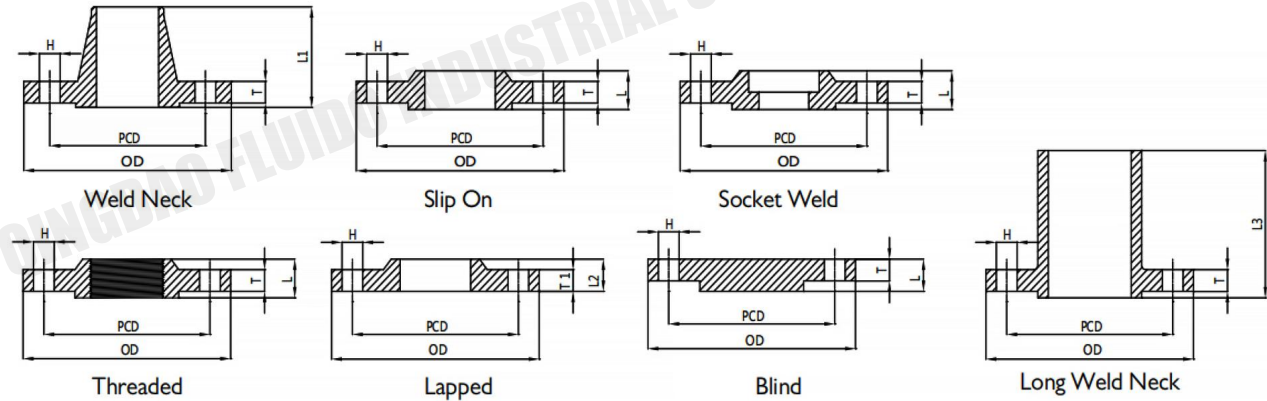

Nominal Pipe Size		Flange Outside Diameter	Flange Thickness		Bossed Length	Weld Neck Length *	Lap Joint Length	Long Weld Neck Length	Drilline Data			Class 150	
			Thickness of Flange Min	Thickness of Lap Min					Pitch Circle Diameter	Bolt Hole Diameter	Number of Bolt Holes	Nominal Pipe Size	
MM	INCH	OD	T	T1	L	L1	L2	L3	PCD	H	#	MM	INCH
15	1/2	90	9.6	11.2	16	46	16	229	60.3	16	4	15	1/2
20	3/4	100	11.2	12.7	16	51	16	229	69.9	16	4	20	3/4
25	1	110	12.7	14.3	17	54	17	229	79.4	16	4	25	1
32	1-1/4	115	14.3	15.9	21	56	21	229	88.9	16	4	32	1-1/4
40	1-1/2	125	15.9	17.5	22	60	22	229	98.4	16	4	40	1-1/2
50	2	150	17.5	19.1	25	62	25	229	120.7	20	4	50	2
65	2-1/2	180	20.7	22.3	29	68	29	229	139.7	20	4	65	2-1/2
80	3	190	22.3	23.9	30	68	30	229	152.4	20	4	80	3
90	3-1/2	215	22.3	23.9	32	70	32	229	177.8	20	8	90	3-1/2
100	4	230	22.3	23.9	33	75	33	229	190.5	20	8	100	4
125	5	255	22.3	23.9	36	87	36	305	215.9	23	8	125	5
150	6	280	23.9	25.4	40	87	40	305	241.3	23	8	150	6
200	8	345	27	28.6	44	100	44	305	298.5	23	8	200	8
250	10	405	28.6	30.2	49	100	49	305	362	26	12	250	10
300	12	485	30.2	31.8	56	113	56	305	431.8	26	12	300	12
350	14	535	33.4	35	57	125	79	305	476.3	29	12	350	14
400	16	595	35	36.6	64	125	87	305	539.8	29	16	400	16
450	18	635	38.1	39.7	69	138	97	305	577.9	32	16	450	18
500	20	700	41.3	42.9	73	143	103	305	635	32	20	500	20
600	24	815	46.1	47.7	83	151	111	305	749.3	25	20	600	24

Note:

- 1.Pipe schedule for WN and SW flanges should be indicated in the inquiry.
- 2.All dimensions are in mm. If you could not find the size, please contact Fluido sales team info@eathu.com.

ASME B 16.5-2013 Class 300 Flange

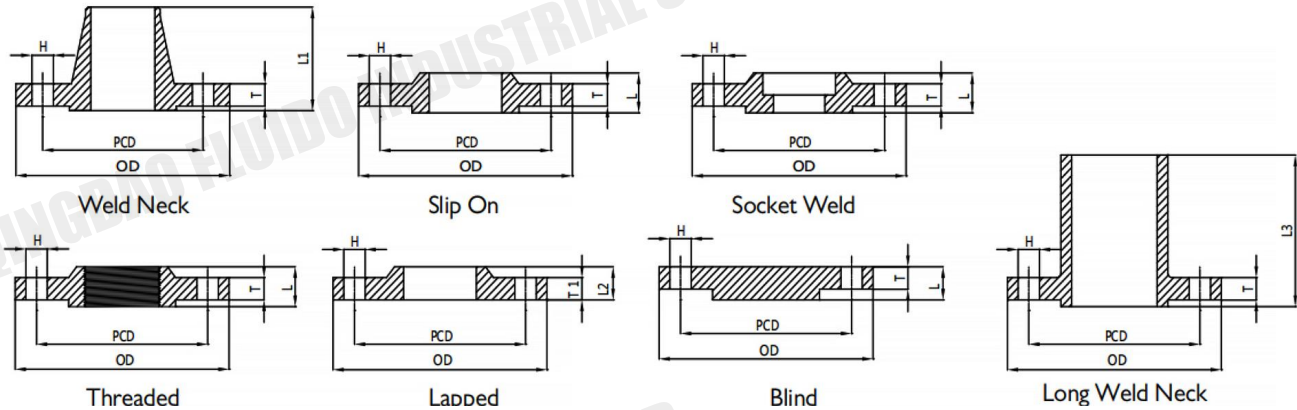

Nominal Pipe Size		Flange Outside Diameter	Flange Thickness		Bossed Length	Weld Neck Length *	Lap Joint Length	Long Weld Neck Length	Drilline Data			Class 300	
			Thickness of Flange Min	Thickness of Lap Min					Pitch Circle Diameter	Bolt Hole Diameter	Number of Bolt Holes	Nominal Pipe Size	
MM	INCH	OD	T	T1	L	L1	L2	L3	PCD	H	#	MM	INCH
15	1/2	95	12.7	14.3	21	51	22	229	66.7	16	4	15	1/2
20	3/4	115	14.3	15.9	24	56	25	229	82.6	20	4	20	3/4
25	1	125	15.9	17.5	25	60	27	229	88.9	20	4	25	1
32	1-1/4	135	17.5	19.1	25	64	27	229	98.4	20	4	32	1-1/4
40	1-1/2	155	19.1	20.7	29	67	30	229	114.3	23	4	40	1-1/2
50	2	165	20.7	22.3	32	68	33	229	127	20	8	50	2
65	2-1/2	190	23.9	25.4	37	75	38	229	149.2	23	8	65	2-1/2
80	3	210	27	28.6	41	78	43	229	168.3	23	8	80	3
90	3-1/2	230	28.6	30.2	43	79	44	229	184.2	23	8	90	3-1/2
100	4	255	30.2	31.8	46	84	48	229	200	23	8	100	4
125	5	280	33.4	35	49	97	51	305	235	23	8	125	5
150	6	320	35	36.6	51	97	52	305	269.9	23	12	150	6
200	8	380	39.7	41.3	60	110	62	305	330.2	26	12	200	8
250	10	445	46.1	47.7	65	116	95	305	387.4	29	16	250	10
300	12	520	49.3	50.8	71	129	102	305	450.8	32	16	300	12
350	14	585	52.4	54	75	141	111	305	514.4	32	20	350	14
400	16	650	55.6	57.2	81	144	121	305	571.5	35	20	400	16
450	18	710	58.8	60.4	87	157	130	305	628.6	35	24	450	18
500	20	775	62	63.5	94	160	140	305	685.8	35	24	500	20
600	24	915	68.3	69.9	105	167	152	305	812.8	42	24	600	24

Note:

- 1.Pipe schedule for WN and SW flanges should be indicated in the inquiry.
- 2.All dimensions are in mm. If you could not find the size, please contact Fluido sales team info@eathu.com.

ASME B 16.5-2013 Class 400 Flange

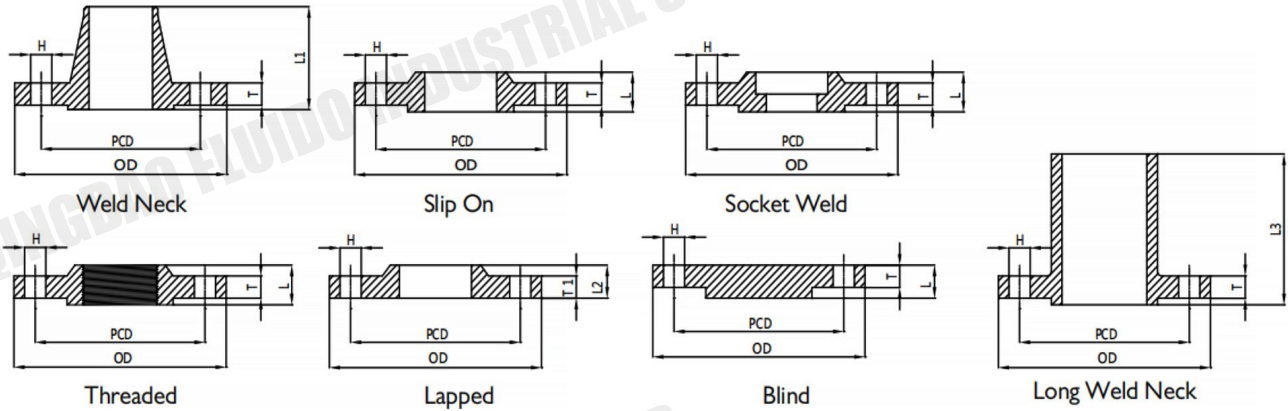

Nominal Pipe Size		Flange Outside Diameter	Thickness of Flange Min	Bossed Length	Weld Neck Length *	Lap Joint Length	Long Weld Neck Length	Drilline Data			Class 400	
								Pitch Circle Diameter	Bolt Hole Diameter	Number of Bolt Holes	Nominal Pipe Size	
MM	INCH	OD	T & T1	L	L1	L2	L3	PCD	H	#	MM	INCH
15	1/2	95	14.3	29	59	22	229	66.7	16	4	15	1/2
20	3/4	115	15.9	32	64	25	229	82.6	20	4	20	3/4
25	1	125	17.5	34	69	27	229	88.9	20	4	25	1
32	1-1/4	135	20.7	36	74	29	229	98.4	20	4	32	1-1/4
40	1-1/2	155	22.3	39	77	32	229	114.3	22	4	40	1-1/2
50	2	165	25.4	44	80	37	229	127	20	8	50	2
65	2-1/2	190	28.6	48	86	41	229	149.2	22	8	65	2-1/2
80	3	210	31.8	53	90	46	229	168.3	22	8	80	3
90	3-1/2	230	35	56	93	49	229	184.2	26	8	90	3-1/2
100	4	255	35	58	96	51	229	200	26	8	100	4
125	5	280	38.1	61	109	54	305	235	26	8	125	5
150	6	320	41.3	64	110	57	305	269.9	26	12	150	6
200	8	380	47.7	75	124	68	305	330	30	12	200	8
250	10	445	54	80	131	102	305	387.4	32	16	250	10
300	12	520	57.2	86	144	108	305	450.8	35	16	300	12
350	14	585	60.4	91	156	117	305	514.4	35	20	350	14
400	16	650	63.5	101	159	127	305	571.5	38	20	400	16
450	18	710	66.7	105	172	137	305	628.6	38	24	450	18
500	20	775	69.9	109	175	146	305	685.8	42	24	500	20
600	24	915	76.2	121	182	159	305	812.8	48	24	600	24

Note:

- 1.Pipe schedule for WN and SW flanges should be indicated in the inquiry.
- 2.All dimensions are in mm. If you could not find the size, please contact Fluido sales team info@eathu.com.

ASME B 16.5-2013 Class 600 Flange

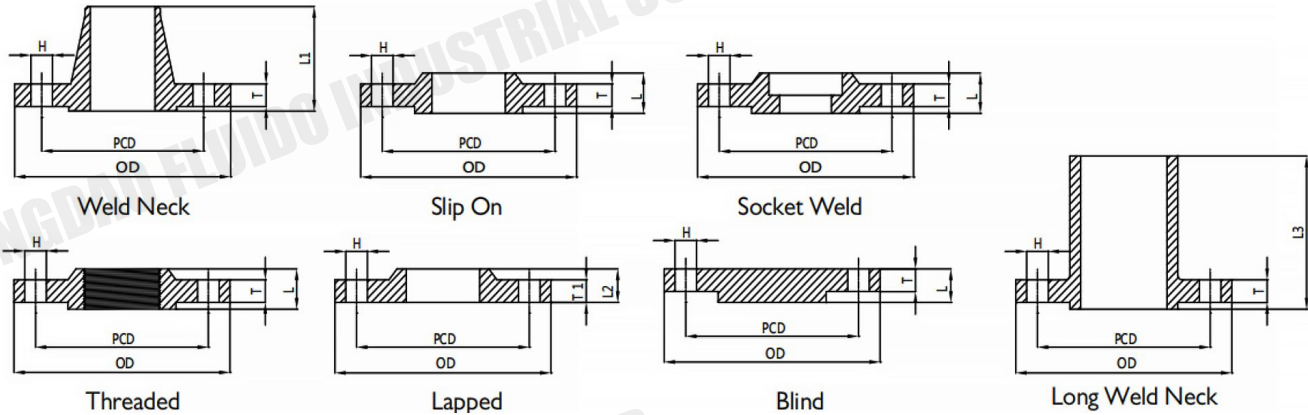

Nominal Pipe Size		Flange Outside Diameter	Thickness of Flange Min	Bossed Length	Weld Neck Length *	Lap Joint Length	Long Weld Neck Length	Drilline Data			Class 600	
								Pitch Circle Diameter	Bolt Hole Diameter	Number of Bolt Holes	Nominal Pipe Size	
MM	INCH	OD	T & T1	L	L1	L2	L3	PCD	H	#	MM	INCH
15	1/2	95	14.3	29	59	22	229	66.7	16	4	15	1/2
20	3/4	115	15.9	32	64	25	229	82.6	20	4	20	3/4
25	1	125	17.5	34	69	27	229	88.9	20	4	25	1
32	1-1/4	135	20.7	36	74	29	229	98.4	20	4	32	1-1/4
40	1-1/2	155	22.3	39	77	32	229	114.3	22	4	40	1-1/2
50	2	165	25.4	44	80	37	229	127	20	8	50	2
65	2-1/2	190	28.6	48	86	41	229	149.2	22	8	65	2-1/2
80	3	210	31.8	53	90	46	229	168.3	22	8	80	3
90	3-1/2	230	35	56	93	49	229	184.2	26	8	90	3-1/2
100	4	275	38.1	61	109	54	229	215.9	26	8	100	4
125	5	330	44.5	67	121	60	305	266.7	29	8	125	5
150	6	355	47.7	74	124	67	305	292.1	29	12	150	6
200	8	420	55.6	83	140	76	305	349.2	32	12	200	8
250	10	510	63.5	93	159	111	305	431.8	35	16	250	10
300	12	560	66.7	99	163	117	305	489	35	20	300	12
350	14	605	69.9	101	172	127	305	527	38	20	350	14
400	16	685	76.2	113	185	140	305	603.2	42	20	400	16
450	18	745	82.6	124	191	152	305	654	45	20	450	18
500	20	815	88.9	134	197	165	305	723.9	45	24	500	20
600	24	940	101.6	147	210	184	305	838.2	51	24	600	24

Note:

1. Pipe schedule for WN and SW flanges should be indicated in the inquiry.
2. All dimensions are in mm. If you could not find the size, please contact Fluido sales team info@eathu.com.

ASME B 16.5-2013 Class 900 Flange

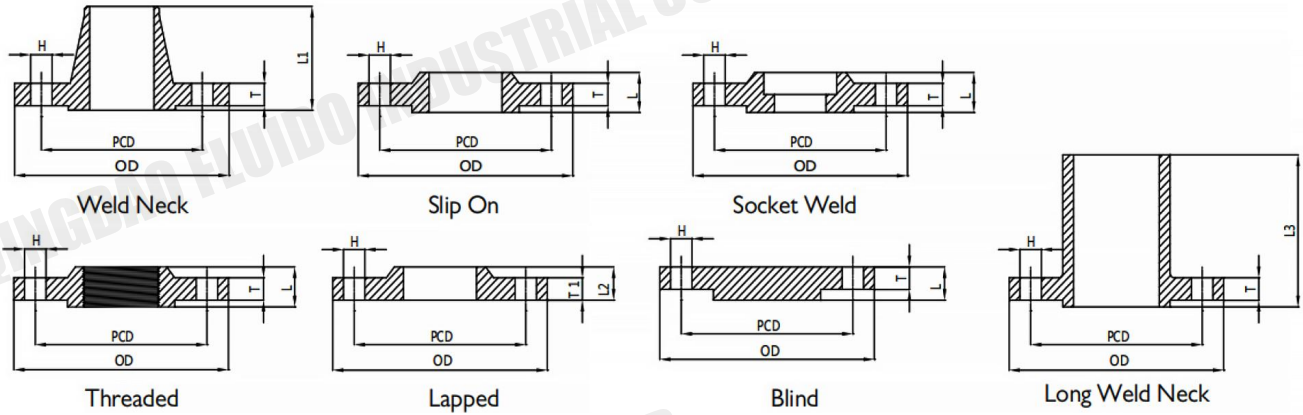

Nominal Pipe Size		Flange Outside Diameter	Thickness of Flange Min	Bossed Length	Weld Neck Length *	Lap Joint Length	Long Weld Neck Length	Drilline Data			Class 900	
								Pitch Circle Diameter	Bolt Hole Diameter	Number of Bolt Holes	Nominal Pipe Size	
MM	INCH	OD	T & T1	L	L1	L2	L3	PCD	PCD	#	MM	INCH
15	1/2	120	22.5	39	67	32	229	82.6	82.6	4	15	1/2
20	3/4	130	25.5	42	77	35	229	88.9	88.9	4	20	3/4
25	1	150	29	48	80	41	229	101.6	101.6	4	25	1
32	1-1/4	160	29	48	80	41	229	111.1	111.1	4	32	1-1/4
40	1-1/2	180	32	51	90	44	229	123.8	123.8	4	40	1-1/2
50	2	215	38.5	64	109	57	229	165.1	165.1	8	50	2
65	2-1/2	245	41.5	71	112	64	229	190.5	190.5	8	65	2-1/2
80	3	265	38.1	61	109	54	229	190.5	190.5	8	80	3
100	4	290	44.5	77	121	70	229	235	235	8	100	4
125	5	350	50.8	86	134	79	305	279.4	279.4	8	125	5
150	6	380	55.6	93	147	86	305	317.5	317.5	12	150	6
200	8	470	63.5	109	169	114	305	393.7	393.7	12	200	8
250	10	545	69.9	115	191	127	305	469.9	469.9	16	250	10
300	12	610	79.4	124	207	143	305	533.4	533.4	20	300	12
350	14	640	85.8	137	220	156	305	558.8	558.8	20	350	14
400	16	705	88.9	140	223	165	305	616	616	20	400	16
450	18	785	101.6	159	236	190	305	685.8	685.8	20	450	18
500	20	855	108	166	255	210	305	749.3	749.3	20	500	20
600	24	1040	139.7	210	299	267	305	901.7	901.7	20	600	24

Note:

- 1.Pipe schedule for WN and SW flanges should be indicated in the inquiry.
- 2.All dimensions are in mm. If you could not find the size, please contact Fluido sales team info@eathu.com.

ASME B 16.5-2013 Class 1500 Flange

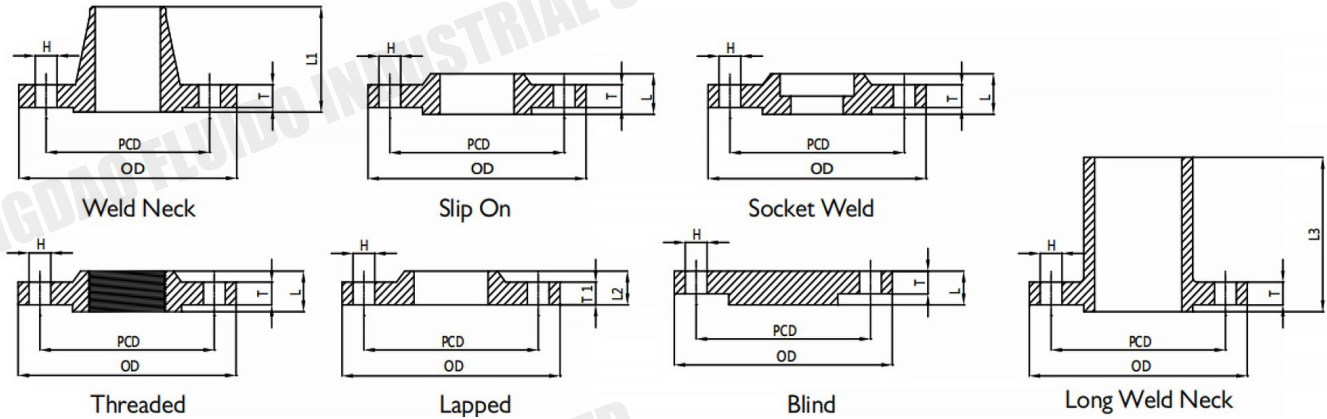

Nominal Pipe Size		Flange Outside Diameter	Thickness of Flange Min	Bossed Length	Weld Neck Length *	Lap Joint Length	Long Weld Neck Length	Drilline Data			Class 1500	
								Pitch Circle Diameter	Bolt Hole Diameter	Number of Bolt Holes	Nominal Pipe Size	
MM	INCH	OD	T & T1		L1	L2	L3	PCD	H	#	MM	INCH
15	1/2	120	22.5		67	32	229	82.6	22	4	15	1/2
20	3/4	130	25.5		77	35	229	88.9	22	4	20	3/4
25	1	150	29		80	41	229	101.6	26	4	25	1
32	1-1/4	160	29		80	41	229	111.1	26	4	32	1-1/4
40	1-1/2	180	32		90	44	229	123.8	29	4	40	1-1/2
50	2	215	38.5	L	109	57	229	165.1	26	8	50	2
65	2-1/2	245	41.5	39	112	64	229	190.5	29	8	65	2-1/2
80	3	265	48	42	124	73	229	203.2	32	8	80	3
100	4	310	54	48	131	90	229	241.3	35	8	100	4
125	5	375	73.5	48	163	105	305	292.1	42	8	125	5
150	6	395	83	51	178	119	305	317.5	38	12	150	6
200	8	485	92	64	220	143	305	393.7	45	12	200	8
250	10	585	108	71	261	178	305	482.6	51	12	250	10
300	12	675	124		290	219	305	571.5	54	16	300	12
350	14	750	133.5		305	241	305	635	60	16	350	14
400	16	825	146.5		318	260	311	704.8	67	16	400	16
450	18	915	162		334	276	327	774.7	73	16	450	18
500	20	985	178		363	292	356	831.8	79	16	500	20
600	24	1170	203.5		413	330	406	990.6	92	16	600	24

Note:

1. Pipe schedule for WN and SW flanges should be indicated in the inquiry.
2. All dimensions are in mm. If you could not find the size, please contact Fluido sales team info@eathu.com.

ASME B 16.5-2013 Class 2500 Flange

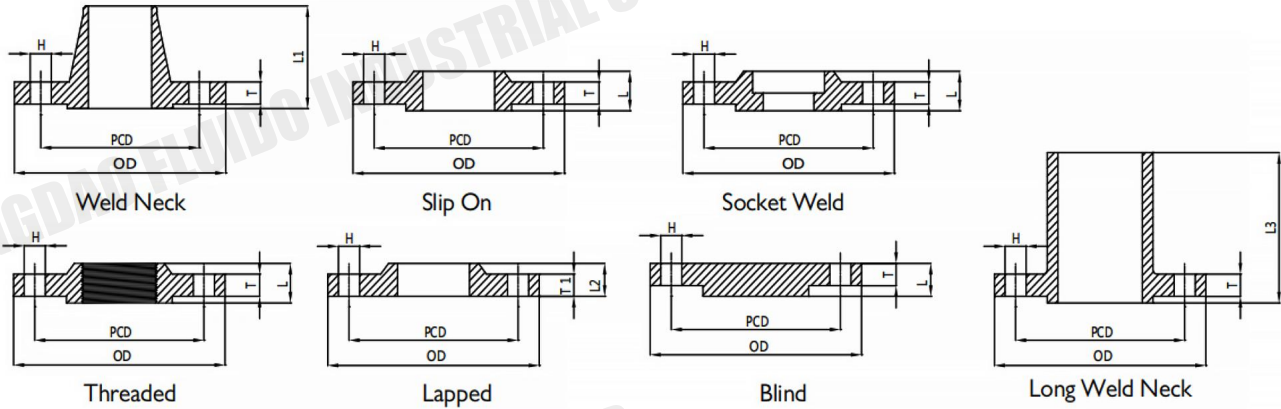

Nominal Pipe Size		Flange Outside Diameter	Thickness of Flange Min	Bossed Length	Weld Neck Length *	Lap Joint Length	Long Weld Neck Length	Drilline Data			Class 2500	
								Pitch Circle Diameter	Bolt Hole Diameter	Number of Bolt Holes	Nominal Pipe Size	
MM	INCH	OD	T & T1	L	L1	L2	L3	PCD	H	#	MM	INCH
15	1/2	135	30.2	47	80	40	229	88.9	22	4	15	1/2
20	3/4	140	31.8	50	86	43	229	95.2	22	4	20	3/4
25	1	160	35	55	96	48	229	108	26	4	25	1
32	1-1/4	185	38.1	59	102	52	229	130.2	29	4	32	1-1/4
40	1-1/2	205	44.5	67	118	60	229	146	32	4	40	1-1/2
50	2	235	50.9	77	134	70	229	171.4	29	8	50	2
65	2-1/2	265	57.2	86	150	79	229	196.8	32	8	65	2-1/2
80	3	305	66.7		175	92	229	228.6	35	8	80	3
100	4	355	76.2		197	108	305	273	42	8	100	4
125	5	420	92.1		235	130	305	323.8	48	8	125	5
150	6	485	108		280	152	305	368.3	54	8	150	6
200	8	550	127		324	178	305	438.2	54	12	200	8
250	10	675	165.1		426	229	406	539.8	67	12	250	10
300	12	760	184.2		471	254	406	619.1	73	12	300	12

Note:

- 1.Pipe schedule for WN and SW flanges should be indicated in the inquiry.
- 2.All dimensions are in mm. If you could not find the size, please contact Fluido sales team info@eathu.com.

ASME B 16.47 - 2011 Class 150 Series A Flange

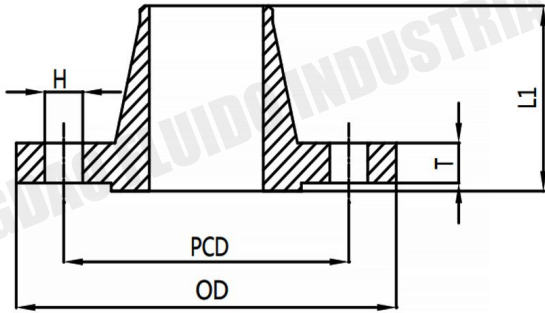

Large Bore Weld Neck
Flanges ASME B16.47A

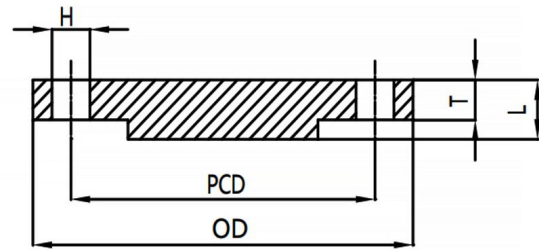

Large Bore Blind Flanges
ASME B16.47A

Class 150 Series A		Nominal Pipe Size			Weld Neck Length	Drillline Data			Class 150 Series A	
Flange Outside Diameter		Flange Outside Diameter	Thickness of W/N Min	Thickness of Blind Min		Pitch Circle Diameter	Bolt Hole Diameter	Number of Bolt Holes	Nominal Pipe Size	
MM	INCH	OD	T	T1	L1	PCD	H	#	MM	INCH
650	26	870	66.7	66.7	119	806.4	1(3/8)	24	650	26
700	28	925	69.9	69.9	124	863.6	1(3/8)	28	700	28
750	30	985	73.1	73.1	135	914.4	1(3/8)	28	750	30
800	32	1060	79.4	79.4	143	977.9	1(5/8)	28	800	32
850	34	1110	81	81	148	1028.7	1(5/8)	32	850	34
900	36	1170	88.9	88.9	156	1085.8	1(5/8)	32	900	36
950	38	1240	85.8	85.8	156	1149.4	1(5/8)	32	950	38
1000	40	1290	88.9	88.9	162	1200.2	1(5/8)	36	1000	40
1050	42	1345	95.3	95.3	170	1257.3	1(5/8)	36	1050	42
1100	44	1405	100.1	100.1	176	1314.4	1(5/8)	40	1100	44
1150	46	1455	101.6	101.6	184	1365.2	1(5/8)	40	1150	46
1200	48	1510	106.4	106.4	191	1422.4	1(5/8)	44	1200	48
1250	50	1570	109.6	109.6	202	1479.6	1(7/8)	44	1250	50
1300	52	1625	114.3	114.3	208	1536.7	1(7/8)	44	1300	52
1350	54	1685	119.1	119.1	214	1593.8	1(7/8)	44	1350	54
1400	56	1745	122.3	122.3	227	1651	1(7/8)	48	1400	56
1450	58	1805	127	127	233	1708.2	1(7/8)	48	1450	58
1500	60	1855	130.2	130.2	238	1759	1(7/8)	52	1500	60

Note:

1. Pipe schedule for WN and SW flanges should be indicated in the inquiry.
2. All dimensions are in mm. If you could not find the size, please contact Fluido sales team info@eathu.com.

ASME B 16.47- 2011 Ring Grooves Class 300-900 Flange

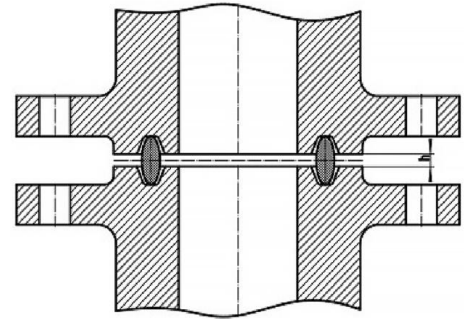
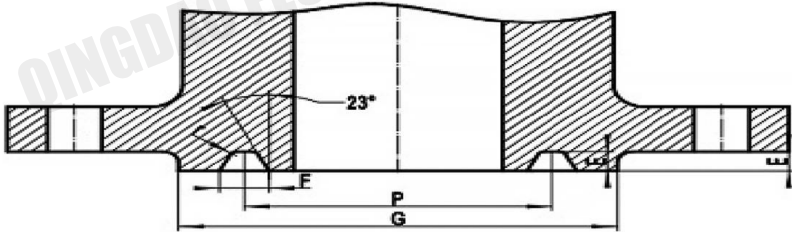

All dimensions are in mm. If you could not find the size, please contact Fluido sales team info@eathu.com.

A typical ring joint flanged connection conforming to ASME B16.47. It consists of two B16.47 RTJ flanges, a metal ring gasket, and necessary bolting.

Nominal Pipe Size For Class			Groove Number	Pitch Diameter	Depth	Width	Radius At Base	Diameter Rf Section
300	600	900						
				A	B	C	D	E
650(26")	650(26")		R93	749.3	0.5	0.781	1.5	810
700(28")	700(28")		R94	800.1	0.5	0.781	1.5	861
750(30")	750(30")		R95	857.25	0.5	0.781	1.5	917
800(32")	800(32")		R96	914.4	0.562	0.906	1.5	984
850(34")	850(34")		R97	965.2	0.562	0.906	1.5	1035
900(36")	900(36")		R98	1022.35	0.562	0.906	1.5	1092
		650(26")	R100	749.3	0.688	1.188	2.3	832
		700(28")	R101	800.1	0.688	1.312	2.3	889
		750(30")	R102	857.25	0.688	1.312	2.3	946
		800(32")	R103	914.4	0.688	1.312	2.3	1003
		850(34")	R104	965.2	0.812	1.438	2.3	1067
		900(36")	R105	1022.35	0.812	1.438	2.3	1124

Note:

All dimensions are in mm. If you could not find the size, please contact Fluido sales team info@eathu.com.

ASME B 16.48-2010 Spectacles, Spades & Spacers Flange

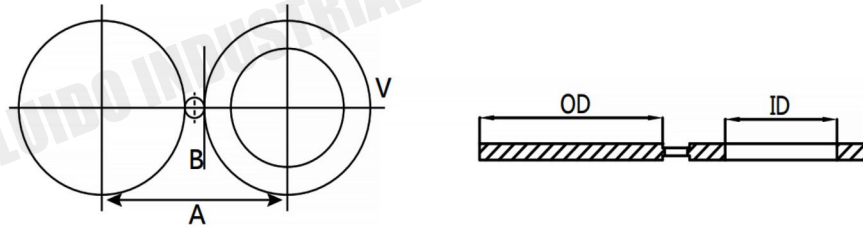

Class 150							Class 300					Class 600						
Nominal pipe Size		Diameter	Outside Diameter	Centre Line Spacing	Thickness Min	Web Width	Inside Diameter	Outside Diameter	Centre Line Spacing	Thickness Min	Web Width	Inside Diameter	Outside Diameter	Centre Line Spacing	Thickness Min	Web Width	Nominal pipe Size	
MM	INCH	ID	OD	A	T	B	ID	OD	A	T	B	ID	OD	A	T	B	MM	INCH
15	1/2	16	45	60	3	38	16	51	65	6.4	38	16	51	65	6.4	38	15	1/2
20	3/4	21	54	70	3	38	21	64	80	6.4	38	21	64	80	6.4	38	20	3/4
25	1	27	64	80	3	38	27	70	90	6.4	38	27	70	90	6.4	57	25	1
32	1-1/4	42	73	90	6.4	38	42	79	100	6.4	38	37	79	100	9.7	57	32	1-1/4
40	1-1/2	48	83	100	6.4	38	48	92	115	6.4	38	43	92	115	9.7	67	40	1-1/2
50	2	61	102	120	6.4	51	61	108	125	9.7	51	55	108	125	9.7	57	50	2
65	2-1/2	73	107	140	6.4	51	73	127	150	9.7	51	67	127	150	12.7	67	65	2-1/2
80	3	89	133	150	6.4	64	89	146	170	9.7	64	83	146	170	12.7	67	80	3
90	3-1/2	102	159	175	9.7	64	102	162	185	12.7	64	96	159	185	15.7	76	90	3-1/2
100	4	114	172	190	9.7	64	114	178	200	12.7	64	108	191	215	15.7	76	100	4
125	5	141	194	215	9.7	76	141	213	235	15.7	76	135	238	265	19.1	86	125	5
150	6	168	219	240	12.7	76	168	248	270	15.7	76	162	264	290	22.4	86	150	6
200	8	219	276	300	12.7	76	219	305	330	22.4	76	212	318	350	28.4	95	200	8
250	10	273	337	360	15.7	102	273	359	385	25.4	102	265	397	430	35.1	105	250	10
300	12	324	406	430	19.1	102	324	419	450	28.5	102	315	454	490	41.1	105	300	12
350	14	356	448	475	19.1	108	356	483	515	31.8	108	346	489	525	44.5	114	350	14
400	16	406	511	460	22.4	108	406	536	570	38.1	108	397	562	605	50.8	124	400	16
450	18	457	546	580	25.4	114	457	594	630	41.1	114	448	610	655	53.9	133	450	18
500	20	508	603	635	28.4	121	508	651	685	44.5	121	497	680	725	63.5	133	500	20
600	24	610	714	750	31.8	140	610	772	810	50.8	140	597	787	840	73.2	152	600	24

Class 900						Class 1500					Class 2500							
Nominal pipe Size		Diameter	Outside Diameter	Centre Line Spacing	Thickness Min	Web Width	Inside Diameter	Outside Diameter	Centre Line Spacing	Thickness Min	Web Width	Inside Diameter	Outside Diameter	Centre Line Spacing	Thickness Min	Web Width	Nominal pipe Size	
MM	INCH	ID	OD	A	T	B	ID	OD	A	T	B	ID	OD	A	T	B	MM	INCH
15	1/2	16	60	80	6.4	38	16	61	80	6.4	38	16	67	90	9.7	38	15	1/2
20	3/4	21	67	90	6.4	41	21	67	90	9.7	41	21	73	95	9.7	41	20	3/4
25	1	27	76	100	6.4	57	27	76	100	9.7	64	27	83	110	9.7	64	25	1
32	1-1/4	37	86	110	9.7	57	35	86	110	9.7	64	35	102	130	12.7	64	32	1-1/4
40	1-1/2	43	95	125	9.7	67	41	95	125	12.7	70	41	114	145	15.7	70	40	1-1/2
50	2	55	140	165	12.7	57	53	140	165	12.7	70	53	143	170	15.7	70	50	2
65	2-1/2	67	162	190	12.7	67	63	162	190	15.7	76	63	165	195	19.1	76	65	2-1/2
80	3	83	165	190	15.7	67	78	172	205	19.1	76	78	194	230	22.4	76	80	3
100	4	108	203	235	19.1	76	102	206	240	22.4	89	102	232	275	28.4	89	100	4
125	5	135	244	280	22.4	86	128	251	290	28.4	89	128	276	325	35.1	89	125	5
150	6	162	286	320	25.4	86	154	279	320	35.1	89	154	314	370	41.1	89	150	6
200	8	212	356	395	35.1	95	203	349	395	41.1	102	198	384	440	53.8	102	200	8
250	10	265	432	470	41.1	105	255	432	480	50.8	114	248	473	540	66.5	114	250	10
300	12	315	495	535	47.8	105	303	518	570	60.5	114	289	546	620	79.2	114	300	12
350	14	346	518	560	53.8	114	333	575	635	66.5	127	N/A	N/A	N/A	N/A	N/A	350	14
400	16	397	572	615	60.5	124	381	638	705	76.2	133	N/A	N/A	N/A	N/A	N/A	400	16
450	18	448	635	685	66.5	133	429	702	775	85.9	146	N/A	N/A	N/A	N/A	N/A	450	18
500	20	497	696	750	73.2	133	478	752	830	95.3	152	N/A	N/A	N/A	N/A	N/A	500	20
600	24	597	835	900	88.9	152	575	899	990	111.3	178	N/A	N/A	N/A	N/A	N/A	600	24

Note: All dimensions are in mm. If you could not find the size, please contact Fluido sales team info@eathu.com.

ASME B 16.36-2009 Orifice Flanges

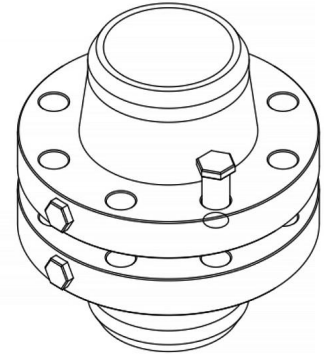
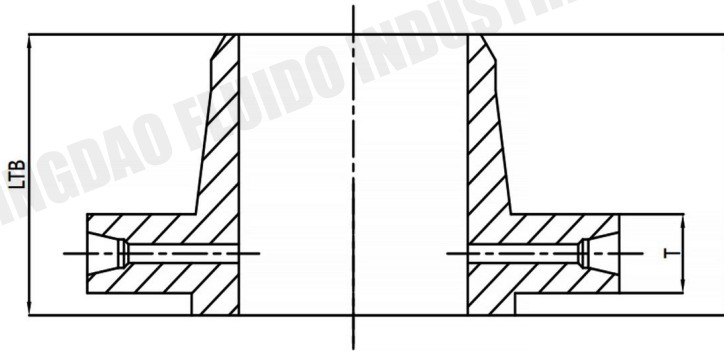

Orifice Flanges

Nominal Pipe Size		Class 300		Class 600		Class 900		Class 1500		Class 2500		Nominal Pipe Size	
		Thickness Min	Length Thru Hub W/Neck	Thickness Min	Length Thru Hub W/Neck	Thickness Min	Length Thru Hub W/Neck	Thickness Min	Length Thru Hub W/Neck	Thickness Min	Length Thru Hub W/Neck		
MM	INCH	T	LTB	T	LTB	T	LTB	T	LTB	T	LTB	MM	INCH
25	1	36.6	83	36.6	83	38.1	89	38.1	89	38.1	98	25	1
40	1-1/2	36.6	86	36.6	86	38.1	95	38.1	95	44.5	117	40	1-1/2
50	2	36.6	86	36.6	86	38.1	108	38.1	108	50.8	133	50	2
65	2-1/2	36.6	89	36.6	89	41.3	111	41.3	111	57.2	149	65	2-1/2
80	3	36.6	89	36.6	89	38.1	108	47.7	123	66.7	174	80	3
100	4	36.6	92	38.1	109	44.5	120	54	130	76.2	196	100	4
150	6	36.6	100	47.8	124	55.6	146	82.6	177	108	279	150	6
200	8	39.7	112	55.6	140	63.5	168	92.1	219	127	324	200	8
250	10	46.1	118	63.5	159	69.9	190	108	260	165.1	425	250	10
300	12	49.3	131	66.7	163	79.4	206	123.9	289	184.2	170	300	12
350	14	52.4	143	69.9	172	85.8	219	133.4	304			350	14
400	16	55.6	146	76.2	185	88.9	222	146.1	317			400	16
450	18	58.8	159	82.6	191	101.6	235	162	333			450	18
500	20	62	162	88.9	197	108	254	177.8	362			500	20
600	24	68.3	169	101.6	210	139.7	298	203.2	412			600	24

Note:

All dimensions are in mm. If you could not find the size, please contact Fluido sales team info@eathu.com.

AWWA RING FLANGE CLASS B AWWA C207

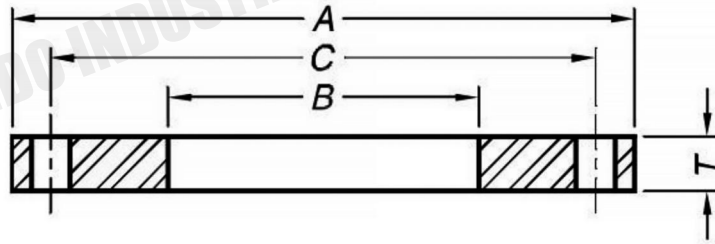

NPS	DN	OD, A	ID, B	Number of Bolts	Diam. of Bolt Circle, C	Diam. of Bolt	Thickness of Flange, T	Thickness of Blind, T
4	100	228.6	116.08	8	190.5	15.88	15.88	15.88
5	125	254	143.76	8	215.9	19.05	15.88	15.88
6	150	279.4	170.69	8	241.3	19.05	17.48	17.48
8	200	342.9	221.49	8	298.45	19.05	17.48	17.48
10	250	406.4	276.35	12	361.95	22.23	17.48	17.48
12	300	482.6	327.15	12	431.8	22.23	17.48	18.26
14	350	533.4	360.43	12	476.25	25.4	17.48	20.1
16	400	596.9	411.23	16	539.75	25.4	17.48	22.66
18	450	635	462.03	16	577.85	28.58	17.48	24.13
20	500	698.5	512.83	20	635	28.58	17.48	26.42
22	550	749.3	563.63	20	692.15	31.75	19.05	28.74
24	600	812.8	614.43	20	749.3	31.75	19.05	30.89
26	650	869.95		24	806.45	31.75	20.62	33.2
28	700	927.1		28	863.6	31.75	22.23	35.5
30	750	984.25		28	914.4	31.75	22.23	37.53
32	800	1060.45		28	977.9	38.1	23.83	40.16
34	850	1111.25		32	1028.7	38.1	23.83	42.19
36	900	1168.4		32	1085.85	38.1	25.4	44.48
38	950	1238.25		32	1149.35	38.1	25.4	47.06
40	1000	1289.05		36	1200.15	38.1	25.4	49.09
42	1050	1346.2		36	1257.3	38.1	28.58	51.4
44	1100	1403.35		40	1314.45	38.1	28.58	53.7
46	1150	1454.15		40	1365.25	38.1	28.58	55.73
48	1200	1511.3		44	1422.4	38.1	31.75	58.03
50	1250	1568.45		44	1479.55	44.45	31.75	60.38
52	1300	1625.6		44	1536.7	44.45	31.75	62.69
54	1350	1682.75		44	1593.85	44.45	34.93	64.99
60	1500	1854.2		52	1758.95	44.45	38.1	71.63
66	1650	2032		52	1930.4	44.45	41.28	78.53
72	1800	2197.1		60	2095.5	44.45	44.45	85.17
78	1950	2362.2		64	2260.6	50.8	50.8	
84	2100	2533.65		64	2425.7	50.8	50.8	
90	2250	2705.1		68	2590.8	57.15	57.15	
96	2400	2876.55		68	2755.9	57.15	57.15	
102	2550	3048		72	2908.3	63.5	63.5	
108	2700	3219.45		72	3067.05	63.5	63.5	
114	2850	3390.9		76	3219.45	69.85	69.85	
120	3000	3562.35		76	3371.85	69.85	69.85	
126	3150	3733.8		80	3536.95	76.2	76.2	
132	3300	3905.25		80	3702.05	76.2	76.2	
144	3600	4248.15		84	4019.55	82.55	82.55	

Note: All dimensions are in mm. If you could not find the size, please contact Fluido sales team info@eathu.com.

AWWA RING FLANGE CLASS D AWWA C207

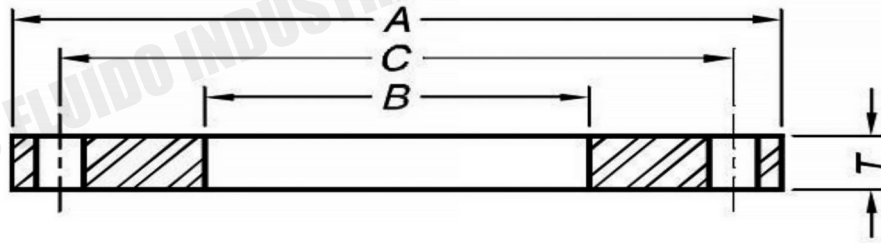

NPS	DN	OD, A	ID, B	Number of Bolts	Diam. of Bolt Circle, C	Diam. of Bolt	Thickness of Flange, T	Thickness of Blind, T
4	100	228.6	116.078	8	190.5	15.88	15.88	15.88
5	125	254	143.764	8	215.9	19.05	15.88	16.51
6	150	279.4	170.688	8	241.3	19.05	17.48	17.59
8	200	342.9	221.488	8	298.45	19.05	17.48	20.62
10	250	406.4	276.352	12	361.95	22.23	17.48	24.21
12	300	482.6	327.152	12	431.8	22.23	20.62	28.37
14	350	533.4	360.426	12	476.25	25.4	23.83	28.78
16	400	596.9	411.226	16	539.75	25.4	25.4	32.13
18	450	635	462.026	16	577.85	28.58	26.97	33.81
20	500	698.5	512.826	20	635	28.58	28.58	36.77
22	550	749.3	563.626	20	692.15	31.75	30.18	39.83
24	600	812.8	614.426	20	749.3	31.75	31.75	42.18
26	650	869.95		24	806.45	31.75	33.32	45.37
28	700	927.1		28	863.6	31.75	33.32	48.4
30	750	984.25		28	914.4	31.75	34.93	51
32	800	1060.45		28	977.9	38.1	38.1	54.6
34	850	1111.25		32	1028.7	38.1	38.1	57.21
36	900	1168.4		32	1085.85	38.1	41.28	60.2
38	950	1238.25		32	1149.35	38.1	41.28	63.66
40	1000	1289.05		36	1200.15	38.1	41.28	66.28
42	1050	1346.2		36	1257.3	38.1	44.45	69.32
44	1100	1403.35		40	1314.45	38.1	44.45	72.36
46	1150	1454.15		40	1365.25	38.1	44.45	74.99
48	1200	1511.3		44	1422.4	38.1	47.63	78.03
50	1250	1568.45		44	1479.55	44.45	50.8	81.18
52	1300	1625.6		44	1536.7	44.45	50.8	84.21
54	1350	1682.75		44	1593.85	44.45	53.98	87.25
60	1500	1854.2		52	1758.95	44.45	57.15	95.97
66	1650	2032		52	1930.4	44.45	63.5	105.6
72	1800	2197.1		60	2095.5	44.45	66.68	113.8
78	1950	2362.2		64	2260.6	50.8	69.85	
84	2100	2533.65		64	2425.7	50.8	73.03	
90	2250	2705.1		68	2590.8	57.15	76.2	
96	2400	2876.55		68	2755.9	57.15	82.55	
102	2550	3048		72	2908.3	63.5	82.55	
108	2700	3219.45		72	3067.05	63.5	85.73	
114	2850	3390.9		76	3219.45	69.85	88.9	
120	3000	3562.35		76	3371.85	69.85	88.9	
126	3150	3733.8		80	3536.95	76.2	95.25	
132	3300	3905.25		80	3702.05	76.2	98.43	
144	3600	4248.15		84	4019.55	82.55	104.78	

Note: All dimensions are in mm. If you could not find the size, please contact Fluido sales team info@eathu.com.

AWWA RING FLANGE CLASS E AWWA C207

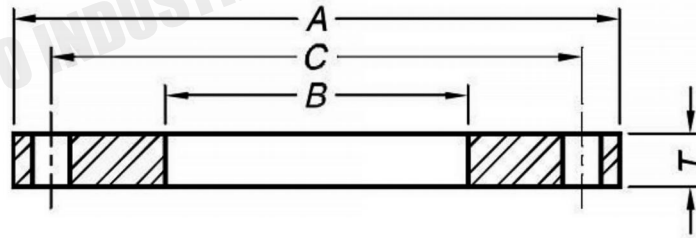

NPS	DN	OD, A	ID, B	Number of Bolts	Diam.of Bolt Circle, C	Diam.of Bolt	Thickness of Flange, T	Thickness of Blind, T
4	100	228.6	116.08	8	190.5	15.88	15.88	28.58
5	125	254	143.76	8	215.9	19.05	19.05	30.18
6	150	279.4	170.69	8	241.3	19.05	19.05	33.35
8	200	342.9	221.49	8	298.45	19.05	19.05	38.1
10	250	406.4	276.35	12	361.95	22.23	22.23	39.7
12	300	482.6	327.15	12	431.8	22.23	22.23	44.45
14	350	533.4	360.43	12	476.25	25.4	25.4	47.63
16	400	596.9	411.23	16	539.75	25.4	25.4	50.8
18	450	635	462.03	16	577.85	28.58	28.58	53.98
20	500	698.5	512.83	20	635	28.58	28.58	60.33
22	550	749.3	563.63	20	692.15	31.75	31.75	63.5
24	600	812.8	614.43	20	749.3	31.75	31.75	66.68
26	650	869.95		24	806.45	31.75	31.75	69.85
28	700	927.1		28	863.6	31.75	31.75	69.85
30	750	984.25		28	914.4	31.75	31.75	73.03
32	800	1060.45		28	977.9	38.1	38.1	76.2
34	850	1111.25		32	1028.7	38.1	38.1	77.46
36	900	1168.4		32	1085.85	38.1	38.1	81.51
38	950	1238.25		32	1149.35	38.1	38.1	86.2
40	1000	1289.05		36	1200.15	38.1	38.1	89.74
42	1050	1346.2		36	1257.3	38.1	38.1	93.86
44	1100	1403.35		40	1314.45	38.1	38.1	97.97
46	1150	1454.15		40	1365.25	38.1	38.1	101.53
48	1200	1511.3		44	1422.4	38.1	38.1	105.65
50	1250	1568.45		44	1479.55	44.45	44.45	109.9
52	1300	1625.6		44	1536.7	44.45	44.45	114.02
54	1350	1682.75		44	1593.85	44.45	44.45	118.14
60	1500	1854.2		52	1758.95	44.45	44.45	129.95
66	1650	2032		52	1930.4	44.45	44.45	142.26
72	1800	2197.1		60	2095.5	44.45	44.45	154.08
78	1950	2362.2		64	2260.6	50.8	50.8	
84	2100	2533.65		64	2425.7	50.8	50.8	
90	2250	2705.1		68	2590.8	57.15	57.15	
96	2400	2876.55		68	2755.9	57.15	57.15	
102	2550	3048		72	2908.3	63.5	63.5	
108	2700	3219.45		72	3067.05	63.5	63.5	
114	2850	3390.9		76	3219.45	69.85	69.85	
120	3000	3562.35		76	3371.85	69.85	69.85	
126	3150	3733.8		80	3536.95	76.2	76.2	
132	3300	3905.25		80	3702.05	76.2	76.2	
144	3600	4248.15		84	4019.55	82.55	82.55	

Note: All dimensions are in mm. If you could not find the size, please contact Fluido sales team info@eathu.com.

AWWA RING FLANGE CLASS F AWWA C207

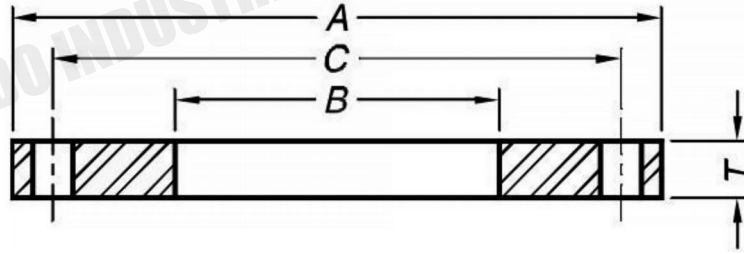

NPS	DN	OD, A	ID, B	Number of Bolts	Diam.of Bolt Circle, C	Diam.of Bolt	Thickness of Flange, T	Thickness of Blind, T
4	100	254	116.08	8	200.15	19.05	28.7	28.7
5	125	279.4	143.76	8	234.95	19.05	30.73	30.73
6	150	317.5	170.94	12	269.75	19.05	33.27	33.27
8	200	381	221.74	12	330.2	22.23	33.27	33.27
10	250	444.5	276.35	16	387.35	25.4	38.1	38.1
12	300	520.7	327.15	16	450.85	28.58	41.4	41.4
14	350	584.2	360.43	20	514.35	28.58	49.28	49.28
16	400	647.7	411.23	20	571.5	31.75	54.36	54.36
18	450	711.2	462.03	24	628.65	31.75	57.15	57.125
20	500	774.7	512.83	24	685.8	31.75	59.18	59.18
22	550	838.2	563.63	24	742.95	31.75	63.5	63.5
24	600	914.4	614.43	24	812.8	38.1	68.33	68.53
26	650	971.55		28	876.3	44.45	76.2	76.2
28	700	1035.05		28	939.8	44.45	79.5	79.5
30	750	1092.2		28	996.95	44.45	80.01	80.42
32	800	1149.35		28	1054.1	44.45	82.55	84.62
34	850	1206.5		28	1104.9	44.45	85.85	88.25
36	900	1270		32	1168.4	50.8	87.88	93.25
38	950	1327.15		32	1219.2	50.8	88.9	96.9
40	1000	1377.95		36	1276.35	50.8	92.2	101.4
42	1050	1447.8		36	1339.85	50.8	96.77	105.92
44	1100	1504.95		36	1397	50.8	101.6	110.19
46	1150	1562.1		40	1454.15	50.8	104.9	114.43
48	1200	1651		40	1543.05	50.8	114.3	121.44

Note: All dimensions are in mm. If you could not find the size, please contact Fluido sales team info@eathu.com.

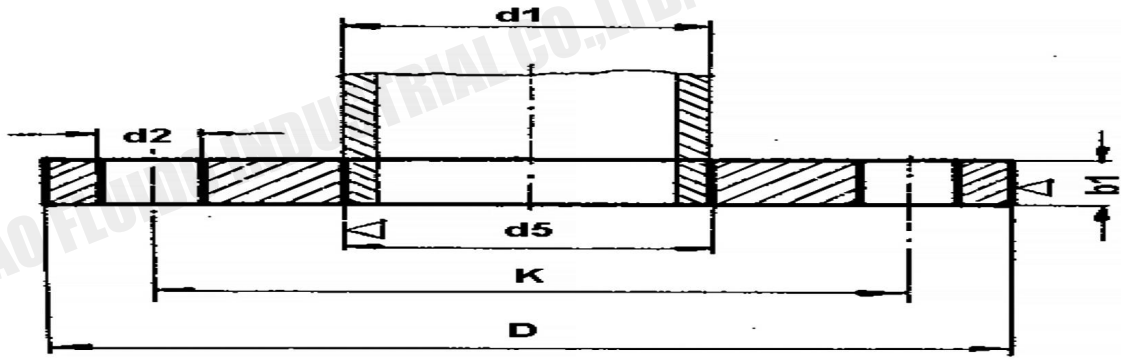

DIN 2576 PN10/16 Flange Dimensions

PIPE			FLANGE				BOLT			Approx Weight Kg
Pressure	DN	d1	d5	D	b1	K	no.	Bolt	d2	
PN 10/16	15	21.3	22	95	14	65	4	M12 (1/2")	14	0.67
PN 10/16	20	26.9	27.6	105	16	75	4	M12 (1/2")	14	0.94
PN 10/16	25	33.7	34.4	115	16	85	4	M12 (1/2")	14	1.11
PN 10/16	32	42.4	43.1	140	16	100	4	M16 (5/8")	18	1.62
PN 10/16	40	48.3	49	150	16	110	4	M16 (5/8")	18	1.86
PN 10/16	50	60.3	61.1	165	18	125	4	M16 (5/8")	18	2.47
PN 10/16	65	76.1	77.1	185	18	145	4	M16 (5/8")	18	3.00
PN 10	80	88.9	90.3	200	20	160	4	M16 (5/8")	18	3.79
PN 10/16	100	108	109.6	220	20	180	8	M16 (5/8")	18	4.20
PN 10/16	100	114.3	115.9	220	20	180	8	M16 (5/8")	18	4.03
PN 10/16	125	139.7	141.6	250	22	210	8	M16 (5/8")	18	5.46
PN 10/16	125	133	134.8	250	22	210	8	M16 (5/8")	18	5.46
PN 10/16	150	168.3	170.5	285	22	240	8	M20 (3/4")	22	6.57
PN 10/16	150	159	161.1	285	22	240	8	M20 (3/4")	22	6.57
PN 10/16	175	193.7	196.1	315	24	270	8	M20 (3/4")	22	8.45
PN 10	200	219.1	221.8	340	24	295	8	M20 (3/4")	22	9.31
PN 10	250	273	276.2	395	26	350	12	M20 (3/4")	22	11.90
PN 10	300	323.9	327.6	445	26	400	12	M20 (3/4")	22	13.80
PN 10	350	355.6	359.7	505	28	460	16	M20 (3/4")	22	20.60
PN 10	400	406.4	411	565	32	515	16	M24 (7/8")	26	27.90
PN 10	450	457	462.3	615	38	565	20	M24 (7/8")	26	35.60
PN 10	500	508	513.6	670	38	620	20	M24 (7/8")	26	41.10
PN 10	600	610	616.5	780	34	725	20	M27	30	44.20
PN 10	700	711	716	895	40	840	24	M27	30	56.05
PN 10	800	813	818	1015	44	950	24	M30	33	78.66
PN 10	900	914	920	1115	48	1050	28	M30	33	99.38
PN 10	1000	1016	1022	1230	50	1160	28	M33	36	122.55

Note: All dimensions are in mm. If you could not find the size, please contact Fluido sales team info@eathu.com.

DIN 2502 PN 16 Flange Dimensions

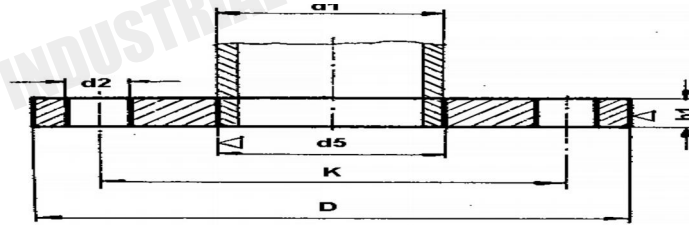

PIPE		FLANGE				BOLT			Approx Weight Kg
DN	d_1	d_5	D	b_1	K	no.	Bolt	d_2	
80	88.9	90.3	200	20	160	8	M16	18	3.79
200	219.1	221.8	340	24	295	12	M20	22	9.31
250	273	276.2	405	26	355	12	M24	26	13.40
300	323.9	327.6	460	28	410	12	M24	26	17.40
350	355.6	359.7	520	30	470	16	M24	26	28.60
400	406.4	411	580	32	525	16	M27	30	30.90
450	457	462.3	640	38	585	20	M27	30	46.00
500	508	513.6	715	38	650	20	M30	33	54.00
600	610	616.5	840	42	770	20	M33	36	77.64
700	711	716	910	44	840	24	M33	36	77.19
800	813	818	1025	50	950	24	M36	39	106.43
900	914	920	1125	54	1050	28	M36	39	125.48
1000	1016	1022	1255	60	1170	28	M39	42	178.12

DIN2566 Threaded Flange With Neck PN16

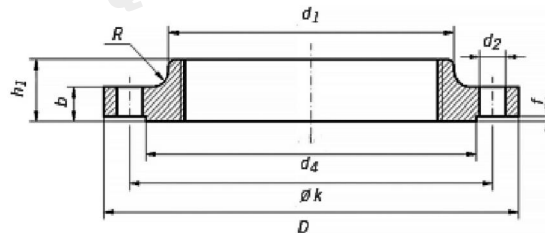

DN	d_1	DIN 2999	D	b	K	h	d_3	d_4	f	No. of holes	d_2	KG
6	10.2	R1/8	75	12	50	18	20	32	2	4	11	0.33
8	13.5	R1/4	80	12	55	18	25	38	2	4	11	0.39
10	17.2	R3/8	90	14	60	20	30	40	2	4	14	0.56
15	21.3	R1/2	95	14	65	20	35	45	2	4	14	0.62
20	26.9	R3/4	105	16	75	24	45	58	2	4	14	0.92
25	33.7	R1	115	16	85	24	52	68	2	4	14	1.1
32	42.4	R1.1/4	140	16	100	26	60	78	2	4	18	1.59
40	48.3	R1.1/2	150	16	110	26	70	88	3	4	18	1.77
50	60.3	R2	165	18	125	28	85	102	3	4	18	2.41
65	76.1	R2.1/2	185	18	145	32	105	122	3	4	18	3.13
80	88.9	R3	200	20	160	34	118	138	3	4	18	3.95
100	114.3	R4	220	20	180	38	140	158	3	8	18	4.38
125	139.7	R3	250	22	210	40	168	188	3	8	18	5.99
150	168.3	R4	285	22	240	44	196	212	3	8	22	7.42

Note: All dimensions are in mm. If you could not find the size, please contact Fluido sales team info@eathu.com.

DIN2527 PN10 Blind Flanges

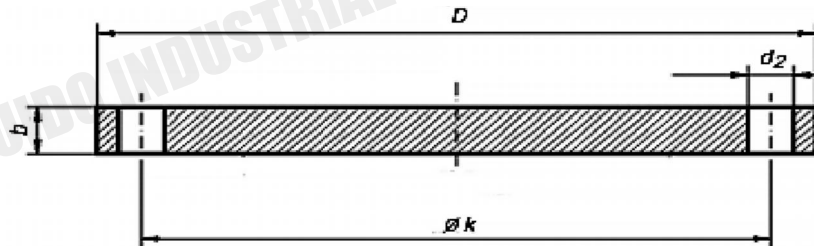

DN	No. of holes	PN6					PN10				
		D	b	k	d2	KG	D	b	k	d2	KG
10	4	75	12	50	11	0.38	90	14	60	14	0.63
15	4	80	12	55	11	0.44	95	14	65	14	0.71
20	4	90	14	65	11	0.66	105	16	75	14	1.01
25	4	100	14	75	11	0.82	115	16	85	14	1.23
32	4	120	14	90	14	1.18	140	16	100	18	1.81
40	4	130	14	100	14	1.39	150	16	110	18	2.09
50	4	140	14	110	14	1.62	165	18	125	18	2.88
65	4	160	14	130	14	2.14	185	18	145	18	3.65
80	4	190	16	150	48	3.43	200	20	160	18	4.61
100	4	210	16	170	18	4.22	220	20	180	18	5.65
125	8	240	18	200	18	6.1	250	22	210	18	8.13
150	8	265	18	225	18	7.51	285	22	240	22	10.49
175	8	295	20	255	18	10.41	315	24	270	22	14.11
200	8	320	20	280	18	12.31	340	24	295	22	16.53
250	12	375	22	335	18	18.55	395	26	350	22	24.08
300	12	440	22	395	22	25.47	445	26	400	22	30.81
350	12	490	22	445	22	31.78	505	26	460	22	39.64
400	16	540	22	495	22	38.5	565	26	515	26	49.44
500	20	645	24	600	22	60.13	670	28	620	26	75.16
600	20	755	28	705	26	96.07	780	30	725	30	109.2
700	24	860	30	810	26	133.8	895	32	840	30	153.77
800	24	975	32	920	30	183.29	1015	36	950	33	222.86
900	24	1075	36	1020	30	251.7	1115	40	1050	33	299.08
1000	28	1175	42	1120	30	350.98	1230	46	1160	36	418.78

DN	No. of holes	PN6					PN10				
		D	b	k	d2	KG	D	b	k	d2	KG
10	4	90	14	60	14	0.63	90	16	60	14	0.72
15	4	95	14	65	14	0.71	95	16	65	14	0.81
20	4	105	16	75	14	1.01	105	18	75	14	1.14
25	4	115	16	85	14	1.23	115	18	85	14	1.38
32	4	140	16	100	18	1.81	140	18	100	18	2.03
40	4	150	16	110	18	2.09	150	18	110	18	2.35
50	4	165	18	125	18	2.88	165	20	125	18	3.2
65	4	185	18	145	18	3.65	185	22	145	18	4.29
80	8	200	20	160	18	4.61	200	24	160	18	5.54
100	8	220	20	180	18	5.65	235	24	190	22	7.6
125	8	250	22	210	18	8.13	270	26	220	26	10.82
150	8	285	22	240	22	10.49	300	28	250	26	14.6
175	8	315	24	270	22	14.11	330	28	280	26	17.4
200	12	340	24	295	22	16.26	360	30	310	26	22.47
250	12	405	26	355	26	24.99	425	32	370	30	33.51
300	12	460	28	410	26	35.13	485	34	430	30	46.29
350	16	520	30	470	26	48.01	555	38	490	33	68.08
400	16	580	32	525	30	83.53	620	40	550	36	89.59
500	20	715	36	650	33	108.63	730	45	660	36	140.66
600	20	780	38	770	36	136.47	845	48	770	39	202.3
700	24	895	40	840	36	189.87	960	50	875	42	271.05
800	24	1015	44	950	39	269.57	1085	54	990	48	373.52
900	28	1115	48	1050	39	355.31	1185	58	1090	48	479.07
1000	28	1230	52	1170	42	469.2	1320	62	1210	56	632.47

Note: All dimensions are in mm. If you could not find the size, please contact Fluido sales team info@eathu.com.

DIN 2631 Weld Neck Flanges PN 6

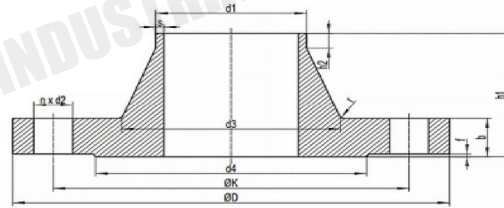

Nominal Diameter	Pipe O.D d1		Flange Dimensions				Hub Dimensions				Raised Face		Bolting Dimensions			WT.
	DN	ISO	DIN	D	b	K	h1	d3	s	r	h2	d4	f	n	bolt	d2
10	-	14.0	75	12	50	28	22	1.8	4	6	35	2	4	M10	11	0.34
	17.2	-	75	12	50	28	26	1.8	4	6	35	2	4	M10	11	0.34
15	-	20.0	80	12	55	30	28	2	4	6	40	2	4	M10	11	0.39
	21.3	-	80	12	55	30	30	2	4	6	40	2	4	M10	11	0.39
20	-	25.0	90	14	65	32	35	2.3	4	6	50	2	4	M10	11	0.59
	26.9	-	90	14	65	32	38	2.3	4	6	50	2	4	M10	11	0.59
25	-	30.0	100	14	75	35	40	2.6	4	6	60	2	4	M10	11	0.75
	33.7	-	100	14	75	35	42	2.6	4	6	60	2	4	M10	11	0.75
32	-	38.0	120	14	90	35	50	2.6	6	6	70	2	4	M12	14	1.05
	42.4	-	120	14	90	35	55	2.6	6	6	70	2	4	M12	14	1.05
40	-	44.5	130	14	100	38	58	2.6	6	7	80	3	4	M12	14	1.18
	48.3	-	130	14	100	38	62	2.6	6	7	80	3	4	M12	14	1.18
50	-	57.0	140	14	110	38	70	2.9	6	8	90	3	4	M12	14	1.34
	60.3	-	140	14	110	38	74	2.9	6	8	90	3	4	M12	14	1.34
65	76.1	76.1	160	14	130	38	88	2.9	6	9	110	3	4	M12	14	1.67
80	88.9	88.9	190	16	150	42	102	3.2	8	10	128	3	4	M16	18	2.71
100	-	108.0	210	16	170	45	122	3.6	8	10	148	3	4	M16	18	3.24
	114.3	-	210	16	170	45	130	3.6	8	10	148	3	4	M16	18	3.26
125	-	133.0	240	18	200	48	148	4	8	10	178	3	8	M16	18	4.49
	139.5	-	240	18	200	48	155	4	8	10	178	3	8	M16	18	4.49
150	-	159.0	265	18	225	48	172	4.5	10	12	202	3	8	M16	18	5.15
	168.3	-	265	18	225	48	184	4.5	10	12	202	3	8	M16	18	5.15
200	219.1	219.1	320	20	280	55	236	5.9	10	15	258	3	8	M16	18	7.82
250	-	267.0	375	22	335	60	282	6.3	12	15	312	3	12	M16	18	10.8
	273.0	-	375	22	335	60	290	6.3	12	15	312	3	12	M16	18	10.8
300	323.9	323.9	440	22	395	62	342	7.1	12	15	365	4	12	M20	22	14
350	355.6	-	490	22	445	62	385	7.1	12	15	415	4	12	M20	22	18.5
	-	368.0	490	22	445	62	385	7.1	12	15	415	4	12	M20	22	16.7
400	406.4	-	540	22	495	65	438	7.1	12	15	465	4	16	M20	22	21.2
	-	419.0	540	22	495	65	438	7.1	12	15	465	4	16	M20	22	19
500	508	508	645	24	600	68	538	7.1	12	15	570	4	20	M20	22	28.6
600	610	610	755	24	705	70	640	7.1	12	16	670	5	20	M24	26	31.5
700	711	711	860	24	810	70	740	7.1	12	16	775	5	24	M24	26	37.4
800	813	813	975	24	920	70	842	7.1	12	16	880	5	24	M27	30	46.1
900	914	914	1075	26	1020	70	942	7.1	12	16	980	5	24	M27	30	55.6
1000	1016	1016	1175	26	1120	70	1045	7.1	16	16	1080	5	28	M27	30	61.9
1200	1220	1220	1405	28	1340	90	1248	8	16	20	1295	5	32	M30	33	100.6
1400	1420	1420	1630	32	1560	90	1452	8	16	20	1510	5	36	M33	36	148
1600	1620	1620	1830	34	1760	90	1655	9	16	20	1710	5	40	M33	36	181
1800	1820	1820	2045	36	1970	100	1855	10	16	20	1920	5	44	M36	39	225
2000	2020	2020	2265	38	2180	110	2058	11	16	25	2125	5	48	M39	42	297
2200	2220	2220	2475	42	2390	115	2260	12	18	25	2335	6	52	M39	42	362
2400	2420	2420	2685	44	2600	125	2462	13	18	25	2545	6	56	M39	42	415
2600	2620	2620	2905	46	2810	130	2665	14	18	25	2750	6	60	M45	48	530
2800	2820	2820	3115	48	3020	135	2865	15	18	30	2960	6	64	M45	48	643
3000	3020	3020	3315	50	3220	140	3068	16	18	30	3160	6	68	M45	48	777
3200	3220	3220	3525	54	3430	150	3272	16	20	30	3370	6	72	M45	48	851
3400	3420	3420	3735	56	3640	160	3475	18	20	35	3580	6	76	M45	48	993
3600	3620	3620	3970	60	3860	165	3678	18	20	35	3790	6	80	M52	56	1002

Note: All dimensions are in mm. If you could not find the size, please contact Fluido sales team info@eathu.com.

DIN 2632 Weld Neck Flanges PN 10

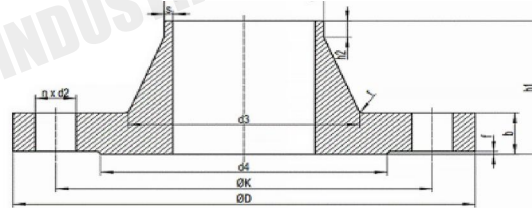

Nominal Diameter	Pipe O.D d1		Flange Dimensions				Hub Dimensions				Raised Face		Bolting Dimensions			WT.
	DN	ISO	DIN	D	b	K	h1	d3	s	r	h2	d4	f	n	bolt	d2
10	-	14.0	90	14	60	35	25	1.8	4	6	40	2	4	M12	14	0.59
	17.2	-	90	14	60	35	28	1.8	4	6	40	2	4	M12	14	0.59
15	-	20.0	95	14	65	35	30	2	4	6	45	2	4	M12	14	0.65
	21.3	-	95	14	65	35	32	2	4	6	45	2	4	M12	14	0.65
20	-	25.0	105	16	75	38	38	2.3	4	6	58	2	4	M12	14	0.95
	26.9	-	105	16	75	38	40	2.3	4	6	58	2	4	M12	14	0.95
25	-	30.0	115	16	85	38	42	2.6	4	6	68	2	4	M12	14	1.14
	33.7	-	115	16	85	38	45	2.6	4	6	68	2	4	M12	14	1.14
32	-	38.0	140	16	100	40	52	2.6	6	6	78	2	4	M16	18	1.69
	42.4	-	140	16	100	40	56	2.6	6	6	78	2	4	M16	18	1.69
40	-	44.5	150	16	110	42	60	2.6	6	7	88	3	4	M16	18	1.86
	48.3	-	150	16	110	42	64	2.6	6	7	88	3	4	M16	18	1.86
50	-	57.0	165	18	125	45	72	2.9	6	8	102	3	4	M16	18	2.53
	60.3	-	165	18	125	45	75	2.9	6	8	102	3	4	M16	18	2.53
65	76.1	76.1	185	18	145	45	90	2.9	6	10	122	3	4	M16	18	3.08
80	88.9	88.9	200	20	160	50	105	3.2	8	10	138	3	8	M16	18	3.72
100	-	108.0	220	20	180	52	125	3.6	8	12	158	3	8	M16	18	4.71
	114.3	-	220	20	180	52	131	3.6	8	12	158	3	8	M16	18	4.71
125	-	133.0	250	22	210	55	150	4	8	12	188	3	8	M16	18	6.4
	139.5	-	250	22	210	55	156	4	8	12	188	3	8	M16	18	6.4
150	-	159.0	285	22	240	55	175	4.5	10	12	212	3	8	M20	22	7.8
	168.3	-	285	22	240	55	184	4.5	10	12	212	3	8	M20	22	7.8
200	219.1	219.1	340	24	295	62	235	5.9	10	16	268	3	8	M20	22	11.4
250	-	267.0	395	26	350	68	285	6.3	12	16	320	3	12	M20	22	14.8
	273.0	-	395	26	350	68	292	6.3	12	16	320	3	12	M20	22	14.8
300	323.9	323.9	445	26	400	68	344	7.1	12	16	370	4	12	M20	22	17.2
350	355.6	-	505	26	460	68	385	7.1	12	16	430	4	16	M20	22	23.6
	-	368.0	505	26	460	68	385	7.1	12	16	430	4	16	M20	22	22.1
400	406.4	-	565	26	515	72	440	7.1	12	16	482	4	16	M24	26	28.3
	-	419.0	565	26	515	72	440	7.1	12	16	482	4	16	M24	26	26.5
450	457.0	457.0	615	28	565	72	488	7.1	12	16	532	4	20	M24	26	31.5
500	508	508	670	28	620	75	542	7.1	12	16	585	4	20	M24	26	38.3
600	610	610	780	28	725	80	642	7.1	12	18	685	5	20	M27	30	44.6
700	711	711	895	30	840	80	745	8	12	18	800	5	24	M27	30	62.4
800	813	813	1015	32	950	90	850	8	12	18	905	5	24	M30	33	84.1
900	914	914	1115	34	1050	95	950	10	12	20	1005	5	28	M30	33	98.5
1000	1016	1016	1230	34	1160	95	1052	10	16	20	1110	5	28	M33	36	115
1200	1220	1220	1455	38	1380	115	1255	11	16	25	1330	5	32	M36	39	182
1400	1420	1420	1675	42	1590	120	1460	12	16	25	1535	5	36	M39	42	248
1600	1620	1620	1915	46	1820	130	1665	14	16	25	1760	5	40	M45	48	348
1800	1820	1820	2115	50	2020	140	1868	15	16	30	1960	5	44	M45	48	429
2000	2020	2020	2325	54	2230	150	2072	16	16	30	2170	5	48	M45	48	540
2200	2220	2220	2550	58	2440	160	2275	18	18	35	2370	6	52	M52	56	658
2400	2420	2420	2760	62	2650	170	2478	20	18	35	2570	6	56	M52	56	825
2600	2620	2620	2960	66	2850	180	2680	22	18	40	2780	6	60	M52	56	979
2800	2820	2820	3180	70	3070	190	2882	22	18	40	3000	6	64	M52	56	1156
3000	3020	3020	3405	75	3290	200	3085	24	18	45	3210	6	68	M56	62	1402

Note: All dimensions are in mm. If you could not find the size, please contact Fluido sales team info@eathu.com.

DIN 2633 Weld Neck Flanges PN16

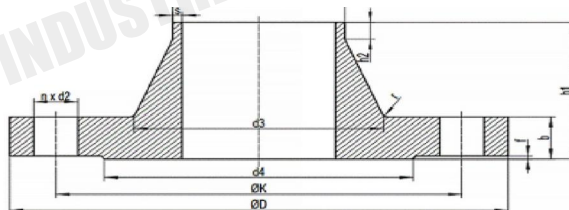

Nominal Diameter	Pipe O.D d1		Flange Dimensions				Hub Dimensions				Raised Face		Bolting Dimensions		WT.	
DN	ISO	DIN	D	b	K	h1	d3	s	r	h2	d4	f	n	bolt	d2	Kgs
10	-	14.0	90	14	60	35	25	1.8	4	6	40	2	4	M12	14	0.59
	17.2	-	90	14	60	35	28	1.8	4	6	40	2	4	M12	14	0.59
15	-	20.0	95	14	65	35	30	2	4	6	45	2	4	M12	14	0.65
	21.3	-	95	14	65	35	32	2	4	6	45	2	4	M12	14	0.65
20	-	25.0	105	16	75	38	38	2.3	4	6	58	2	4	M12	14	0.95
	26.9	-	105	16	75	38	40	2.3	4	6	58	2	4	M12	14	0.95
25	-	30.0	115	16	85	38	42	2.6	4	6	68	2	4	M12	14	1.14
	33.7	-	115	16	85	38	45	2.6	4	6	68	2	4	M12	14	1.14
32	-	38.0	140	16	100	40	52	2.6	6	6	78	2	4	M16	18	1.69
	42.4	-	140	16	100	40	56	2.6	6	6	78	2	4	M16	18	1.69
40	-	44.5	150	16	110	42	60	2.6	6	7	88	3	4	M16	18	1.86
	48.3	-	150	16	110	42	64	2.6	6	7	88	3	4	M16	18	1.86
50	-	57.0	165	18	125	45	72	2.9	6	8	102	3	4	M16	18	2.53
	60.3	-	165	18	125	45	75	2.9	6	8	102	3	4	M16	18	2.53
65	76.1	76.1	185	18	145	45	90	2.9	6	10	122	3	4	M16	18	3.08
80	88.9	88.9	200	20	160	50	105	3.2	8	10	138	3	8	M16	18	3.72
100	-	108.0	220	20	180	52	125	3.6	8	12	158	3	8	M16	18	4.71
	114.3	-	220	20	180	52	131	3.6	8	12	158	3	8	M16	18	4.71
125	-	133.0	250	22	210	55	150	4	8	12	188	3	8	M16	18	6.4
	139.5	-	250	22	210	55	156	4	8	12	188	3	8	M16	18	6.4
150	-	159.0	285	22	240	55	175	4.5	10	12	212	3	8	M20	22	7.8
	168.3	-	285	22	240	55	184	4.5	10	12	212	3	8	M20	22	7.8
200	219.1	219.1	340	24	295	62	235	5.9	10	16	268	3	12	M20	22	11
250	-	267.0	405	26	355	70	285	6.3	12	16	320	3	12	M24	26	15.6
	273.0	-	405	26	355	70	292	6.3	12	16	320	3	12	M24	26	15.6
300	323.9	323.9	460	28	410	78	344	7.1	12	16	378	4	12	M24	26	22.1
	355.6	-	520	30	470	82	390	8	12	16	438	4	16	M24	26	31.3
350	-	368.0	520	30	470	82	390	8	12	16	438	4	16	M24	26	29.2
	406.4	-	580	32	525	85	445	8	12	16	490	4	16	M27	30	39.5
400	-	419.0	580	32	525	85	445	8	12	16	490	4	16	M27	30	37.1
	457.0	457.0	640	34	585	85	490	8	12	16	550	4	20	M27	30	44.3
500	508	508	715	34	650	90	548	8	12	16	610	4	20	M30	33	61.2
600	610	610	840	36	770	95	652	8.8	12	18	725	5	20	M33	36	75.4
700	711	711	910	36	840	100	755	8.8	12	18	795	5	24	M33	36	77.1
800	813	813	1025	38	950	105	855	10	12	20	900	5	24	M36	39	101
900	914	914	1125	40	1050	110	955	10	12	20	1000	5	28	M36	39	122
1000	1016	1016	1255	42	1170	120	1058	10	16	22	1115	5	28	M39	42	162
1200	1220	1220	1485	48	1390	130	1262	13	16	30	1330	5	32	M45	48	243
1400	1420	1420	1685	52	1590	145	1465	14	16	30	1530	5	36	M45	48	323
1600	1620	1620	1930	58	1820	160	1668	16	16	35	1750	5	40	M52	56	479
1800	1820	1820	2130	62	2020	170	1870	18	16	35	1950	5	44	M52	56	599
2000	2020	2020	2345	66	2230	180	2072	20	16	40	2150	5	48	M56	62	719

FLUIDO FLANGE

Note: All dimensions are in mm. If you could not find the size, please contact Fluido sales team info@eathu.com.

DIN2642 Lapped Joint Flange, Plain Collar PN10

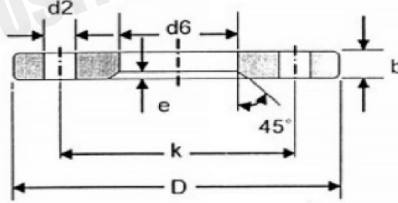

DN	d1		D	d6	b	k	e	No. of holes	d2	KG
	ISO	DIN								
10	-	14	90	16	14	60	3	4	14	0.61
	17.2	-	90	19	14	60	3	4	14	0.6
15	-	20	95	22	14	65	3	4	14	0.67
	21.3	-	95	24	14	65	3	4	14	0.66
20	-	25	105	28	14	75	3	4	14	0.82
	26.9	-	105	30	14	75	3	4	14	0.81
25	-	30	115	33	16	85	4	4	14	1.12
	33.7	-	115	36	16	85	4	4	14	1.1
32	-	38	140	42	16	100	4	4	18	1.63
	42.4	-	140	46	16	100	4	4	18	1.6
40	-	44.5	150	50	16	110	4	4	18	1.85
	48.3	-	150	54	16	110	4	4	18	1.8
50	-	57	165	62	16	125	5	4	18	2.18
	60.3	-	165	65	16	125	5	4	18	2.14
65	76.1	-	185	81	16	145	5	4	18	2.6
80	88.9	-	200	94	18	160	5	8	18	3.17
100	-	108	220	113	18	180	5	8	18	3.67
	114.3	-	220	119	18	180	5	8	18	3.51
125	-	133	250	138	18	210	5	8	18	4.53
	139.7	-	250	145	18	210	5	8	18	4.32
150	-	159	285	164	18	240	5	8	22	5.6
	168.3	-	285	173	18	240	5	8	22	5.26
200	219.1	-	340	225	20	295	5	8	22	7.53
250	-	267	395	273	22	350	5	12	22	10.27
	273	-	395	279	22	350	5	12	22	9.82
300	323.9	-	445	329	26	400	5	12	22	13.46
350	355.6	-	505	362	28	460	6	16	22	20.07
	-	368	505	374	28	460	6	16	22	18.54
400	406.4	-	565	413	32	515	6	16	26	27.19
	-	419	565	426	32	515	6	16	26	25.04
500	508	-	670	517	38	620	6	20	26	39.38
600	610	-	780	618	44	725	7	20	30	56.55
700	711	-	895	721	50	840	7	24	30	80.02
800	813	-	1015	824	56	950	7	24	33	112.25
900	914	-	1115	926	62	1050	7	28	33	135.8
1000	1016	-	1230	1026	70	1160	7	28	36	182.96

Note: All dimensions are in mm. If you could not find the size, please contact Fluido sales team info@eathu.com.

DIN2543 Flat Flange For Welding (Slip On) PN16

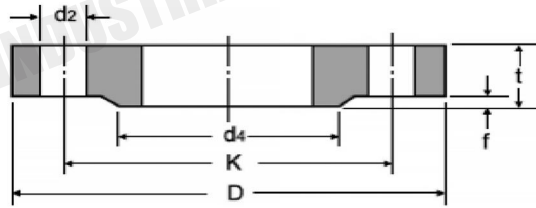

DN	d1		D	d6	b	k	e	No. of holes	d2	KG
	ISO	DIN								
10	17.2	14	40	90	-	2	60	4	4	0.63
15	21.3	20	45	95	14	2	65	4	4	0.72
20	26.9	25	58	105	16	2	75	4	4	1.01
25	33.7	30	68	115	16	2	85	4	4	1.23
32	42.4	38	78	140	16	2	100	4	4	1.8
40	48.3	44.5	88	150	16	3	110	4	4	2.09
50	60.3	57	102	165	18	3	125	4	4	2.88
65	76.1	-	122	185	18	3	145	4	4	3.66
80	88.9	-	138	200	20	3	160	8	8	4.77
100	114.3	108	158	220	20	3	180	8	8	5.65
125	139.7	133	188	250	22	3	210	8	8	8.42
150	168.3	159	212	285	22	3	240	8	8	10.4
200	219.1	216	268	340	24	3	295	12	12	16.1
250	273	267	320	405	26	3	355	12	12	24.9
300	323.9	318	378	460	28	4	410	12	12	35.1
350	355.6	368	438	520	30	4	470	16	16	47.8
400	406.4	419	490	580	32	4	525	16	16	63.5
500	508	521	610	715	36	4	650	20	20	102
600	609.6	622	725	840	40	5	770	20	20	-
700	711.2	720	795	910	-	5	840	24	24	-
800	812.8	820	900	1025	-	5	950	24	24	-
900	914.4	920	1000	1125	-	5	1050	28	28	-
1000	1016	1020	1115	1255	-	5	1170	28	28	-

Flat Flange For Welding (Slip On) PN25

DN	ISO	DIN	d4	D	t	f	K ψ	No. of Holes	d2	KG
10	17.2	14	40	90	-	2	60	4	14	0.72
15	21.3	20	45	95	16	2	65	4	14	0.81
20	26.9	25	58	105	18	2	75	4	14	1.24
25	33.7	30	68	115	18	2	85	4	14	1.38
32	42.4	38	78	140	18	2	100	4	18	2.03
40	48.3	44.5	88	150	18	3	110	4	18	2.35
50	60.3	57	102	165	20	3	125	4	18	3.2
65	76.1	-	122	185	22	3	145	4	18	4.29
80	88.9	-	138	200	24	3	160	8	18	5.88
100	114.3	108	162	235	24	3	190	8	23	7.54
125	139.7	133	188	270	26	3	220	8	27	10.8
150	168.3	159	218	300	28	3	250	8	27	14.5
200	219.1	216	278	360	30	3	310	12	27	22.3
250	273	267	335	425	32	3	370	12	30	33.5
300	323.9	318	395	485	34	4	430	16	30	46.3
350	355.6	368	450	555	38	4	490	16	33	68
400	406.4	419	505	620	40	4	550	16	36	89.7
500	508	521	615	730	44	4	660	20	36	138
600	609.6	622	720	845	-	5	770	20	39	-
700	711.2	720	820	960	-	5	870	24	42	-
800	812.8	820	930	1085	-	5	990	24	48	-
900	914.4	920	1030	1185	-	5	1090	28	48	-
1000	1016	1020	1140	1320	-	5	1210	28	56	-

Note: All dimensions are in mm. If you could not find the size, please contact Fluido sales team info@eathu.com.

DIN 86029 Hubbed Slip-on Flange For Welding PN10

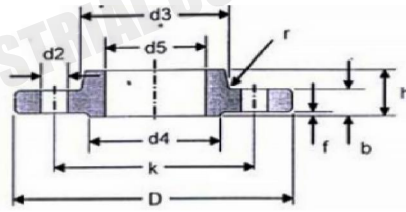

DN	d1	D	d5	b	k	h	d3	r	d4	f	No. of holes	d2	KG
10	17.2	90	17.7	14	60	20	30	4	40	2	4	14	0.56
15	21.3	95	22	14	65	20	35	4	45	2	4	14	0.62
20	26.9	105	27.6	16	75	24	45	4	58	2	4	14	0.91
25	33.7	115	34.4	16	85	24	52	5	68	2	4	14	1.09
32	42.4	140	43.1	16	100	26	60	5	78	2	4	18	1.58
40	48.3	150	49	16	110	26	70	5	88	3	4	18	1.76
50	60.3	165	61.1	18	125	28	85	5	102	3	4	18	2.39
65	76.1	185	77.1	18	145	32	105	5	122	3	4	18	3.1
80	88.9	200	90.3	20	160	34	118	5	138	3	8	18	3.77
100	114.3	220	115.9	20	180	38	140	5	158	3	8	18	4.29
125	139.7	250	141.6	22	210	40	168	5	188	3	8	18	5.86
150	168.3	285	170.5	22	240	44	196	5	212	3	8	22	7.22
175	193.7	315	196.1	24	270	44	224	6	242	3	8	22	9.18
200	219.4	340	222	24	295	44	247	6	268	3	8	22	9.95
250	273	395	276	26	350	46	300	6	320	3	12	22	12.69
300	323.9	445	327	26	400	46	352	6	370	4	12	22	14.4
350	355.6	505	359	26	460	53	398	10	430	4	16	22	22.36
400	406.4	565	410	26	515	57	448	10	482	4	16	26	26.85
450	457	615	461	28	565	62	502	10	532	4	20	26	32.53
500	508	670	512	28	620	67	552	10	585	4	20	26	37.84
600	610	780	614	28	725	75	658	10	685	5	20	30	49.32
700	711	895	716	30	840	77	760	10	800	5	24	30	63.86
800	813	1015	818	32	950	84	864	10	905	5	24	33	85.19
900	914	1115	920	34	1050	88	969	10	1005	5	28	33	101.36
1000	1016	1230	1022	34	1160	92	1071	10	1110	5	28	36	119.72

DIN86030 Hubbed Slip-on Flange For Welding PN16

DN	d1	D	d5	b	k	h	d3	r	d4	f	No. of holes	d2	KG
10	17.2	90	17.7	14	60	20	30	4	40	2	4	14	0.56
15	21.3	95	22	14	65	20	35	4	45	2	4	14	0.62
20	26.9	105	27.6	16	75	24	45	4	58	2	4	14	0.91
25	33.7	115	34.4	16	85	24	52	5	68	2	4	14	1.09
32	42.4	140	43.1	16	100	26	60	5	78	2	4	18	1.58
40	48.3	150	49	16	110	26	70	5	88	3	4	18	1.76
50	60.3	165	61.1	18	125	28	85	5	102	3	4	18	2.39
65	76.1	185	77.1	18	145	32	105	5	122	3	4	18	3.1
80	88.9	200	90.3	20	160	34	118	5	138	3	8	18	3.77
100	114.3	220	115.9	20	180	38	140	5	158	3	8	18	4.29
125	139.7	250	141.6	22	210	40	168	5	188	3	8	18	5.86
150	168.3	285	170.5	22	240	44	196	5	212	3	8	22	7.22
175	193.7	315	196.1	24	270	44	224	6	242	3	8	22	9.18
200	219.4	340	222	24	295	44	247	6	268	3	12	22	9.7
250	273	405	276	26	355	46	300	6	320	3	12	26	13.5
300	323.9	460	327	28	410	46	355	6	378	4	12	26	17.29
350	355.6	520	359	30	470	57	400	10	438	4	16	26	27.68
400	406.4	580	410	32	525	63	457	10	490	4	16	30	36.13
450	457	640	461	34	585	68	505	10	550	4	20	30	44.25
500	508	715	512	34	650	73	559	10	610	4	20	33	56.88
600	610	840	614	36	770	83	664	10	725	5	20	36	80.95
700	711	910	716	36	840	83	760	10	795	5	24	36	76.84
800	813	1025	818	38	950	90	864	10	900	5	24	39	99.34
900	914	1125	920	40	1050	94	969	10	1000	5	28	39	116.63
1000	1016	1255	1022	42	1170	100	1073	10	1115	5	28	42	154.09

Note: All dimensions are in mm. If you could not find the size, please contact Fluido sales team info@eathu.com.

AS2129 TABLE FLANGE

Manufactured to AS 2129 from ASTM A182 Forgings or ASTM A240 Plate

Available in Table D and Table E

Gramophone finish one side

Available bored for pipe or tube, or Blinds and screwed BSP

2205 Flanges: Please enquire with FLUIDO sales team for options. Manufactured from Plate, Global sourcing.

BFP: Bore for Pipe

BFT: Bore for Tube

AS2129 Table D Flange Dimensions

Nominal Pipe Size mm	Slip on Bore	Outside Dia. of Flange	THK	Bolt Circle Dia.	No. Of Holes	Dia. of Holes
15	22.3	95	5	67	4	14
20	27.6	100	5	73	4	14
25	34.5	115	5	83	4	14
32	43.1	120	6	87	4	14
40	49.5	135	6	98	4	14
50	61.9	150	8	114	4	18
65	74.6	165	8	127	4	18
80	90.6	185	10	146	4	18
90	103.3	205	10	165	4	18
100	116	215	10	178	4	18
125	143.7	255	13	210	8	18
150	170.6	280	13	235	8	18
200	221.4	335	13	292	8	18
250	276.3	405	16	356	8	22
300	327.1	455	19	406	12	22
350	359.1	525	22	470	12	26
375	410.4	550	22	495	12	26
400	410.4	580	25	521	12	26
450	461.7	640	25	584	12	26
500	513	705	29	641	16	26
550	564.3	760	29	699	16	30
600	615.9	825	32	756	16	30
700	717.5	910	35	845	20	30
750	768.3	995	41	927	20	33
800	819.1	1060	41	984	20	36
850	869.9	1090	44	1016	20	36
900	920.7	1175	48	1092	24	36

AS2129 Table E Flange Dimensions

Nominal Pipe Size mm	Slip on Bore	Outside Dia. of Flange	THK	Bolt Circle Dia.	No. Of Holes	Dia. of Holes
15	22.3	95	6	67	4	14
20	27.6	100	6	73	4	14
25	34.5	115	7	83	4	14
32	43.1	120	8	87	4	14
40	49.5	135	9	98	4	14
50	61.9	150	10	114	4	18
65	74.6	165	10	127	4	18
80	90.6	185	11	146	4	18
90	103.3	205	12	165	8	18
100	116	215	13	178	8	18
125	143.7	255	14	210	8	18
150	170.6	280	17	235	8	22
200	221.4	335	19	292	8	22
250	276.3	405	22	356	12	22
300	327.1	455	25	406	12	26
350	359.1	525	29	470	12	26
375	410.4	550	32	495	12	26
400	410.4	580	32	521	12	26
450	461.7	640	35	584	16	26
500	513	705	38	641	16	26
550	564.3	760	44	699	16	30
600	615.9	825	48	756	16	33
700	717.5	910	51	845	20	33
750	768.3	995	54	927	20	36
800	819.1	1060	54	984	20	36
850	869.9	1090	57	1016	20	36
900	920.7	1175	64	1092	24	36

AS2129 Table H Flange Dimensions

Nominal Pipe Size mm	Slip on Bore	Outside Dia. of Flange	THK	Bolt Circle Dia.	No. Of Holes	Dia. of Holes
15	22.3	115	13	83	4	18
20	27.6	115	13	83	4	18
25	34.5	120	14	87	4	18
32	43.1	135	17	98	4	18
40	49.5	140	17	105	4	18
50	61.9	165	19	127	4	18
65	74.6	185	19	146	8	18
80	90.6	205	22	165	8	18
90	103.3	215	22	178	8	18
100	116	230	25	191	8	18
125	143.7	280	29	235	8	22
150	170.6	305	29	260	12	22
200	221.4	370	32	324	12	22
250	276.3	430	35	381	12	26
300	327.1	490	41	438	16	26
350	359.1	550	48	495	16	30
400	410.4	610	54	552	20	30
450	461.7	675	60	610	20	33



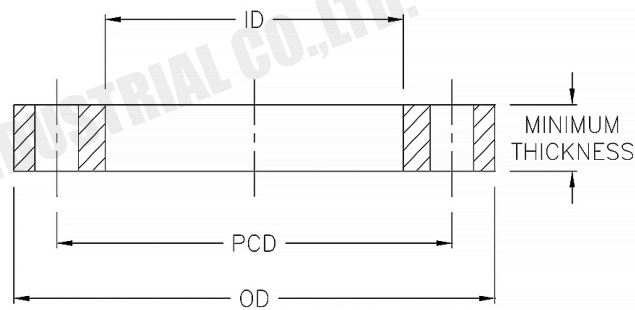

STEEL BACKING FLANGES AS 4087 - Figure B7 PN16

Nominal Pipe OD	Flange Size	OD	ID	Minimum Thickness	PCD	Bolt Hole No. x Dia.	Bolt Size
63	50	150	78	11	114	4X18	M16
75	65	165	92	11	127	4X18	M16
90	80	185	108	11	146	4X18	M16
110	100	215	128	13	178	4X18	M16
160	150	280	178	13	235	8X18	M16
200	200	335	235	19	292	8X18	M16
225	225	370	238	19	324	8X18	M16
250	250	405	288	19	356	8X22	M20
315	300	455	338	23	406	12X22	M20
355	350	525	376	30	470	12X26	M24
n/a	375	550	n/a	30	495	12X26	M24
400	400	580	430	30	521	12X26	M24
450	450	640	470	30	584	12X26	M24
500	500	705	533	38	641	16X26	M24
630	600	825	645	48	756	16X30	M27
710	700	910	740	56	845	20X30	M27
n/a	750	995	n/a	56	927	20X33	M30
800	800	1060	843	56	984	20X36	M33
900	900	1175	947	66	1092	24X36	M33
1000	1000	1255	1050	66	1175	24X36	M33

STEEL BACKING FLANGES AS 4087 - Figure B8 PN21

Nominal Pipe OD	Flange Size	OD	ID	Minimum Thickness	PCD	Bolt Hole No. x Dia.	Bolt Size
63	50	165	78	15	127	4X18	M16
75	65	185	92	15	146	8X18	M16
90	80	205	108	15	165	8X18	M16
110	100	230	128	19	191	8X18	M16
160	150	305	178	24	260	12X22	M20
200	200	370	235	24	324	12X22	M20
225	225	405	238	30	356	12X26	M24
250	250	430	288	30	381	12X26	M24
315	300	490	338	30	438	16X26	M24
355	350	550	376	30	495	16X30	M27
n/a	375	580	n/a	38	521	16X30	M27
400	400	610	430	38	552	20X30	M27
450	450	675	470	38	610	20X33	M30
500	500	735	533	48	673	24X33	M30
630	600	850	645	58	781	24X36	M33
710	700	935	740	58	857	24X36	M33
n/a	750	1015	n/a	58	940	28X36	M33
800	800	1060	843	68	984	28X36	M33
900	900	1185	947	68	1105	32X39	M36
1000	1000	1275	1050	78	1194	36X39	M36

Note: This table has bolting compatibility with AS 2129 Table D flanges. All dimensions are in mm. If you could not find the size, please contact Fluido sales team info@eathu.com. As per ISO 9624: "The inside diameter of the loose backing flange shall conform to the design of the flange adaptor. In some applications, values of the inside diameter of the loose backing flange differing from those given in the tables may be used."

SO Flanges (EN1092.1)

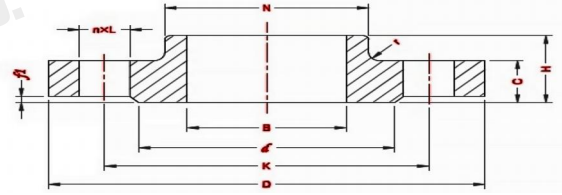

Dimensions of Slip On Flanges PN 6 EN 1092-1

DN	Pipe OD, A		Outside Diamete, D	Diameter of Bolt Circle, K	Dia of Bolt Hole, L	No. of bolt	Diameter of Raised Face, d	Height of Raised Face, f1	Flange thickness, C	Length of Flange, H	Neck Diameter , N		Radius of Corners, r	Bore diameter,B	
	Series I	Series II									Series I	Series II		Series I	Series II
10	17.2	14	75	50	11	4	35	2	12	20	25	4	18	15	
15	21.3	18	80	55	11	4	40	2	12	20	30	4	22	19	
20	26.9	25	90	65	11	4	50	2	14	24	40	4	27.5	26	
25	33.7	32	100	75	11	4	60	2	14	24	50	4	34.5	33	
32	42.4	38	120	90	14	4	70	2	14	26	60	6	43.5	39	
40	48.3	45	130	100	14	4	80	3	14	26	70	6	49.5	46	
50	60.3	57	140	110	14	4	90	3	14	28	80	6	61.5	59	
65	76.1	76	160	130	14	4	110	3	14	32	100	6	77.5	78	
80	88.9	89	190	150	18	4	128	3	16	34	110	8	90.5	91	
100	114.3	108	210	170	18	4	148	3	16	40	130	8	116	110	
125	139.7	133	240	200	18	8	178	3	18	44	160	8	141.5	135	
150	168.3	159	265	225	18	8	202	3	18	44	185	10	170.5	161	
200	219.1	219	320	280	18	8	258	3	20	44	240	10	221.5	222	
250	273	273	375	335	18	12	312	3	22	44	295	12	276.5	276	
300	323.9	325	440	395	22	12	365	4	22	44	355	12	327.5	328	

Dimensions of Slip On Flanges PN 16 EN 1092-1

DN	Pipe OD, A		Outside Diamete, D	Diameter of Bolt Circle, K	Dia of Bolt Hole, L	No. of bolt	Diameter of Raised Face, d	Height of Raised Face, f1	Flange thickness, C	Length of Flange, H	Neck Diameter , N		Radius of Corners, r	Bore diameter,B	
	Series I	Series II									Series I	Series II		Series I	Series II
10	17.2	14	90	60	14	4	40	2	16	22	30	4	18	15	
15	21.3	18	95	65	14	4	45	2	16	22	35	4	22	19	
20	26.9	25	105	75	14	4	58	2	18	26	45	4	27.5	26	
25	33.7	32	115	85	14	4	68	2	18	28	52	4	34.5	33	
32	42.4	38	140	100	18	4	78	2	18	30	60	6	43.5	39	
40	48.3	45	150	110	18	4	88	3	18	32	70	6	49.5	46	
50	60.3	57	165	125	18	4	102	3	18	28	84	6	61.5	59	
65	76.1	76	185	145	18	8	122	3	18	32	104	6	77.5	78	
80	88.9	89	200	160	18	8	138	3	20	34	118	6	90.5	91	
100	114.3	108	220	180	18	8	158	3	20	40	140	8	116	110	
125	139.7	133	250	210	18	8	188	3	22	44	168	8	141.5	135	
150	168.3	159	285	240	22	8	212	3	22	44	195	10	170.5	161	
200	219.1	219	340	295	22	8	268	3	24	44	246	10	221.5	222	
250	273	273	395	350	22	12	320	3	26	46	298	12	276.5	276	
300	323.9	325	445	400	22	12	370	4	26	46	350	12	327.5	328	
350	355.6	377	505	460	22	16	430	4	26	53	400	412	12	359.5	380
400	406.4	426	565	515	26	16	482	4	26	57	456	465	12	411	430
450	457	480	615	565	26	20	532	4	28	63	502	515	12	462	484
500	508	530	670	620	26	20	585	4	28	67	559	570	12	513.5	534
600	610	630	780	725	30	20	685	5	28	75	658	670	12	616.5	634

Dimensions of Slip On Flanges PN 25 EN 1092-1

DN	Pipe OD, A		Outside Diamete, D	Diameter of Bolt Circle, K	Dia of Bolt Hole, L	No. of bolt	Diameter of Raised Face, d	Height of Raised Face, f1	Flange thickness, C	Length of Flange, H	Neck Diameter , N		Radius of Corners, r	Bore diameter,B	
	Series I	Series II									Series I	Series II		Series I	Series II
10	17.2	14	90	60	14	4	40	2	16	22	30	4	18	15	
15	21.3	18	95	65	14	4	45	2	16	22	35	4	22	19	
20	26.9	25	105	75	14	4	58	2	18	26	45	4	27.5	26	
25	33.7	32	115	85	14	4	68	2	18	28	52	4	34.5	33	
32	42.4	38	140	100	18	4	78	2	18	30	60	6	43.5	39	
40	48.3	45	150	110	18	4	88	3	18	32	70	6	49.5	46	
50	60.3	57	165	125	18	4	102	3	20	34	84	6	61.5	59	
65	76.1	76	185	145	18	8	122	3	22	38	104	6	77.5	78	
80	88.9	89	200	160	18	8	138	3	24	40	118	8	90.5	91	
100	114.3	108	235	190	22	8	162	3	24	44	145	8	116	110	
125	139.7	133	270	220	26	8	188	3	26	48	170	8	141.5	135	
150	168.3	159	300	250	26	8	218	3	28	52	200	10	170.5	161	
200	219.1	219	360	310	26	12	278	3	30	52	256	10	221.5	222	
250	273	273	435	370	30	12	335	3	32	60	310	10	276.5	276	
300	323.9	325	485	430	30	16	395	4	34	67	364	10	327.5	328	
350	355.6	377	555	490	33	16	450	4	38	72	418	429	12	359.5	380
400	406.4	426	620	550	36	16	505	4	40	78	472	484	12	411	430
450	457	480	670	600	36	20	555	4	46	84	520	534	12	462	485
500	508	530	730	660	36	20	615	4	48	90	580	594	12	513.5	535
600	610	630	845	770	39	20	720	5	58	100	684	699	12	616.5	636

Dimensions of Slip On Flanges PN 6 EN 1092-1

DN	Pipe OD, A		Outside Diamete, D	Diameter of Bolt Circle, K	Dia of Bolt Hole, L	No. of bolt	Diameter of Raised Face, d	Height of Raised Face, fl	Flange thickness, C	Length of Flange, H	Neck Diameter , N		Radius of Corners, r	Bore diameter,B	
	Series I	Series II									Series I	Series II		Series I	Series II
10	17.2	14	90	60	14	4	40	2	16	22	30		4	18	15
15	21.3	18	95	65	14	4	45	2	16	22	35		4	22	19
20	26.9	25	105	75	14	4	58	2	18	26	45		4	27.5	26
25	33.7	32	115	85	14	4	68	2	18	28	52		4	34.5	33
32	42.4	38	140	100	18	4	78	2	18	30	60		6	43.5	39
40	48.3	45	150	110	18	4	88	3	18	32	70		6	49.5	46
50	60.3	57	165	125	18	4	102	3	20	34	84		6	61.5	59
65	76.1	76	185	145	18	8	122	3	22	38	104		6	77.5	78
80	88.9	89	200	160	18	8	138	3	24	40	118		8	90.5	91
100	114.3	108	235	190	22	8	162	3	24	44	145		8	116	110
125	139.7	133	270	220	26	8	188	3	26	48	170		8	141.5	135
150	168.3	159	300	250	26	8	218	3	28	52	200		10	170.5	161
200	219.1	219	375	320	30	12	285	3	34	52	260		10	221.5	222
250	273	273	450	385	33	12	345	3	38	60	312		12	276.5	276
300	323.9	325	515	450	33	16	410	4	42	67	380		12	327.5	328
350	355.6	377	580	510	36	16	465	4	46	72	424	430	12	359.5	380
400	406.4	426	660	585	39	16	535	4	50	78	478	492	12	411	430
450	457	480	685	610	39	20	560	4	57	84	522	539	12	462	485
500	508	530	755	670	42	20	615	4	57	90	576	594	12	513.5	535
600	610	630	890	795	48	20	735	5	72	100	686	704	12	616.5	636

Dimensions of Slip On Flanges PN 63 EN 1092-1

DN	Pipe OD, A		Outside Diamete, D	Diameter of Bolt Circle, K	Dia of Bolt Hole, L	No. of bolt	Diameter of Raised Face, d	Height of Raised Face, fl	Flange thickness, C	Length of Flange, H	Neck Diameter , N		Radius of Corners, r	Bore diameter,B	
	Series I	Series II									Series I	Series II		Series I	Series II
10	17.2	14	100	70	14	4	4	2	20	28	40		4	18	15
15	21.3	18	105	75	14	4	4	2	20	28	43		4	22	19
20	26.9	25	130	90	18	4	4	2	20	30	52		4	27.5	26
25	33.7	32	140	100	18	4	4	2	24	32	60		4	34.5	33
32	42.4	38	155	110	22	4	4	2	24	32	68		6	43.5	39
40	48.3	45	170	125	22	4	4	3	26	34	80		6	49.5	46
50	60.3	57	180	135	22	4	4	3	26	36	90		6	61.5	59
65	76.1	76	205	160	22	8	8	3	26	40	112		6	77.5	78
80	88.9	89	215	170	22	8	8	3	28	44	125		8	90.5	91
100	114.3	108	250	200	26	8	8	3	30	52	152		8	116	110
125	139.7	133	295	240	30	8	8	3	34	56	185		8	141.5	135
150	168.3	159	345	280	33	8	8	3	36	60	215		10	170.5	161

Dimensions of Slip On Flanges PN 100 EN 1092-1

DN	Pipe OD, A		Outside Diamete, D	Diameter of Bolt Circle, K	Dia of Bolt Hole, L	No. of bolt	Diameter of Raised Face, d	Height of Raised Face, fl	Flange thickness, C	Length of Flange, H	Neck Diameter , N		Radius of Corners, r	Bore diameter,B	
	Series I	Series II									Series I	Series II		Series I	Series II
10	17.2	14	100	70	14	4	40	2	20	28	40		4	18	15
15	21.3	18	105	75	14	4	45	2	20	28	43		4	22	19
20	26.9	25	130	90	18	4	58	2	22	30	52		4	27.5	26
25	33.7	32	140	100	18	4	68	2	24	32	60		4	34.5	33
32	42.4	38	155	110	22	4	78	2	24	32	68		6	43.5	39
40	48.3	45	170	125	22	4	88	3	26	34	80		6	49.5	46
50	60.3	57	195	145	26	4	102	3	28	36	95		6	61.5	59
65	76.1	76	220	170	26	8	122	3	30	40	118		6	77.5	78
80	88.9	89	230	180	26	8	138	3	32	44	130		8	90.5	91
100	114.3	108	265	210	30	8	162	3	36	52	158		8	116	110
125	139.7	133	315	250	33	8	188	3	40	56	188		8	141.5	135
150	168.3	159	355	290	33	12	218	3	44	60	225		10	170.5	161

Note: All dimensions are in mm. If you could not find the size, please contact Fluido sales team info@eathu.com.

WN Flanges (EN1092.1)

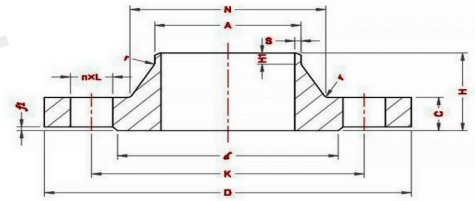

Dimensions of Weld Neck Flanges PN 2.5 EN 1092-1

DN	Pipe OD, A		Outside Diamete, D	Diameter of Bolt Circle, K	Dia of Bolt Hole, L	No. of bolt	Diameter of Raised Face, d	Height of Raised Face, f1	Flange thickness, C	Length of Flange, H	Neck Diameter , N		Wall thickness, S	Length of right end, H1	Radius of Corners, r
	Series I	Series II									Series I	Series II			
10	17.2	14	75	50	11	4	35	2	12	28	26	2	6	4	
15	21.3	18	80	55	11	4	40	2	12	30	30	2	6	4	
20	26.9	25	90	65	11	4	50	2	14	32	38	2.3	6	4	
25	33.7	32	100	75	11	4	60	2	14	35	42	2.6	6	4	
32	42.4	38	120	90	14	4	70	2	14	35	55	2.6	6	6	
40	48.3	45	130	100	14	4	80	3	14	38	62	2.6	7	6	
50	60.3	57	140	110	14	4	90	3	14	38	74	2.9	8	6	
65	76.1	76	160	130	14	4	110	3	14	38	88	2.9	9	6	
80	88.9	89	190	150	18	4	128	3	16	42	102	3.2	10	8	
100	114.3	108	210	170	18	4	148	3	16	45	130	3.6	10	8	
125	139.7	133	240	200	18	8	178	3	18	48	155	4	10	8	
150	168.3	159	265	225	18	8	202	3	18	48	184	4.5	12	10	
200	219.1	219	320	280	18	8	258	3	20	55	236	6.3	15	10	
250	273	273	375	335	18	12	312	3	22	60	290	6.3	15	12	
300	323.9	325	440	395	22	12	365	4	22	62	342	7.1	15	12	
350	355.6	377	490	445	22	12	415	4	22	62	385	390	7.1	15	12
400	406.4	426	540	495	22	16	465	4	22	65	438	440	7.1	15	12
450	457	480	595	550	22	16	520	4	22	65	492	494	7.1	15	12
500	508	530	645	600	22	20	570	4	24	68	538	545	7.1	15	12
600	610	630	755	705	26	20	670	5	30	70	640	650	7.1	16	12
700	711	720	860	810	26	24	775	5	30	76	740	740	7.1	16	12
800	813	820	975	920	30	24	880	5	30	76	842	844	7.1	16	12
900	914	920	1075	1020	30	24	980	5	30	78	942	944	7.1	16	12
1000	1016	1020	1175	1120	30	28	1080	5	30	82	1045		8	16	16
1200	1219	1220	1375	1320	30	32	1280	5	32	94	1245		8	16	16
1400	1422	1420	1575	1520	30	36	1480	5	38	96	1445		8.8	16	16
1600	1626	1620	1790	1730	30	40	1690	5	46	102	1645		10	20	16
1800	1829	1820	1990	1930	30	44	1890	5	46	110	1845		11	20	16
2000	2032	2020	2190	2130	30	48	2090	5	50	122	2045		11	22	16
2200	2235	2220	2405	2340	33	52	2295	5	56	129	2248		11	25	18
2400	2438	2420	2605	2540	33	56	2495	5	62	143	2448		11	25	18
2600	2620		2805	2740	33	60	2695	5	64	148	2648		11	25	18
2800	2820		3030	2960	36	64	2910	5	74	161	2848		11	25	18
3000	3020		3230	3160	36	68	3110	5	80	170	3050		11	25	18
3200	3220		3430	3360	36	72	3310	5	84	180	3250		11	25	20
3400	3420		3630	3560	36	76	3510	5	90	194	3450		11	28	20
3600	3620		3840	3770	36	80	3720	5	96	201	3652		11	28	20
3800	3820		4045	3970	39	80	3920	5	102	212	3852		11	28	20
4000	4020		4245	4170	39	84	4120	5	106	226	4052		11	28	20

Dimensions of Weld Neck Flanges PN 6 EN 1092-1

DN	Pipe OD, A		Outside Diamete, D	Diameter of Bolt Circle, K	Dia of Bolt Hole, L	No. of bolt	Diameter of Raised Face, d	Height of Raised Face, f1	Flange thickness, C	Length of Flange, H	Neck Diameter , N		Wall thickness, S	Length of right end, H1	Radius of Corners, r
	Series I	Series II									Series I	Series II			
10	17.2	14	75	50	11	4	35	2	12	28	26	2	6	4	
15	21.3	18	80	55	11	4	40	2	12	30	30	2	6	4	
20	26.9	25	90	65	11	4	50	2	14	32	38	2.3	6	4	
25	33.7	32	100	75	11	4	60	2	14	35	42	2.6	6	4	
32	42.4	38	120	90	14	4	70	2	14	35	55	2.6	6	6	
40	48.3	45	130	100	14	4	80	3	14	38	62	2.6	7	6	
50	60.3	57	140	110	14	4	90	3	14	38	74	2.9	8	6	
65	76.1	76	160	130	14	4	110	3	14	38	88	2.9	9	6	
80	88.9	89	190	150	18	4	128	3	16	42	102	3.2	10	8	
100	114.3	108	210	170	18	4	148	3	16	45	130	3.6	10	8	
125	139.7	133	240	200	18	8	178	3	18	48	155	4	10	8	
150	168.3	159	265	225	18	8	202	3	18	48	184	4.5	12	10	
200	219.1	219	320	280	18	8	258	3	20	55	236	6.3	15	10	
250	273	273	375	335	18	12	312	3	22	60	290	6.3	15	12	
300	323.9	325	440	395	22	12	365	4	22	62	342	7.1	15	12	
350	355.6	377	490	445	22	12	415	4	22	62	385	390	7.1	15	12
400	406.4	426	540	495	22	16	465	4	22	65	438	440	7.1	15	12
450	457	480	595	550	22	16	520	4	22	65	492	494	7.1	15	12
500	508	530	645	600	22	20	570	4	24	68	538	545	7.1	15	12
600	610	630	755	705	26	20	670	5	30	70	640	650	7.1	16	12
700	711	720	860	810	26	24	775	5	30	76	740	740	8	16	12
800	813	820	975	920	30	24	880	5	30	76	842	844	8	16	12
900	914	920	1075	1020	30	24	980	5	34	78	942	944	8	16	12
1000	1016	1020	1175	1120	30	28	1080	5	38	82	1045		8	16	16
1200	1219	1220	1405	1340	33	32	1295	5	42	104	1248		8.8	20	16
1400	1422	1420	1630	1560	36	36	1510	5	56	114	1452		8.8	20	16
1600	1626	1620	1830	1760	39	40	1710	5	63	119	1655		10	20	16
1800	1829	1820	2045	1970	42	44	1920	5	69	133	1855		11	20	16
2000	2032	2020	2265	2180	42	48	2125	5	74	146	2058		12.5	25	16
2200	2235	2220	2475	2390	42	52	2335	5	81	154	2260		14	25	18
2400	2438	2420	2685	2600	48	56	2545	5	87	168	2462		15	25	18
2600	2620		2905	2810	48	60	2750	5	91	175	2665		16	25	18
2800	2820		3115	3020	48	64	2960	5	101	188	2865		17	30	18
3000	3020		3315	3220	48	68	3160	5	102	192	3068		20	30	18
3200	3220		3525	3430	48	72	3370	5	106	202	3272		20	30	20
3400	3420		3735	3640	48	76	3580	5	110	214	3475		22	35	20
3600	3620		3970	3860	56	80	3790	5	124	229	3678		22	35	20

Dimensions of Weld Neck Flanges PN 10 EN 1092-1

DN	Pipe OD, A		Outside Diameter, D	Diameter of Bolt Circle, K	Dia of Bolt Hole, L	No. of bolt	Diameter of Raised Face, d	Height of Raised Face, f1	Flange thickness, C	Length of Flange, H	Neck Diameter, N		Wall thickness, S	Length of right end, H1	Radius of Corners, r
	Series I	Series II									Series I	Series II			
10	17.2	14	90	60	14	4	40	2	16	35	28		2	6	4
15	21.3	18	95	65	14	4	45	2	16	38	32		2	6	4
20	26.9	25	105	75	14	4	58	2	18	40	40		2.3	6	4
25	33.7	32	115	85	14	4	68	2	18	40	46		2.6	6	4
32	42.4	38	140	100	18	4	78	2	18	42	56		2.6	6	6
40	48.3	45	150	110	18	4	88	3	18	45	64		2.6	7	6
50	60.3	57	165	125	18	4	102	3	18	45	74		2.9	8	6
65	76.1	76	185	145	18	8	122	3	18	45	92		2.9	10	6
80	88.9	89	200	160	18	8	138	3	20	50	105		3.2	10	6
100	114.3	108	220	180	18	8	158	3	20	52	131		3.6	12	8
125	139.7	133	250	210	18	8	188	3	22	55	156		4	12	8
150	168.3	159	285	240	22	8	212	3	22	55	184		4.5	12	10
200	219.1	219	340	295	22	8	268	3	24	62	234		6.3	16	10
250	273	273	395	350	22	12	320	3	26	68	292		6.3	16	12
300	323.9	325	445	400	22	12	370	4	26	68	342		7.1	16	12
350	355.6	377	505	460	22	16	430	4	26	68	385	400	7.1	16	12
400	406.4	426	565	515	26	16	482	4	26	72	440	445	7.1	16	12
450	457	480	615	565	26	20	532	4	28	72	488	500	7.1	16	12
500	508	530	670	620	26	20	585	4	28	75	542	550	7.1	16	12
600	610	630	780	725	30	20	685	5	30	82	642	650	8	18	12
700	711	720	895	840	30	24	800	5	35	85	746		8.8	18	12
800	813	820	1015	950	33	24	905	5	38	96	850		8.8	18	12
900	914	920	1115	1050	33	28	1005	5	38	99	950		12.5	20	12
1000	1016	1020	1230	1160	36	28	1110	5	44	105	1052		12.5	20	16
1200	1219	1220	1455	1380	39	32	1330	5	55	132	1256		12.5	25	16
1400	1422	1420	1675	1590	42	36	1535	5	65	143	1460		14.2	25	16
1600	1626	1620	1915	1820	48	40	1760	5	75	159	1666		16	25	16
1800	1829	1820	2115	2020	48	44	1960	5	85	175	1868		17.5	30	16
2000	2032	2020	2325	2230	48	48	2170	5	90	186	2072		17.5	30	16
2200	2235		2550	2440	56	52	2370	5	100	202	2275		20	35	18
2400	2438		2760	2650	56	56	2570	5	110	218	2478		22.2	35	18
2600	2620		2960	2850	56	60	2780	5	110	224	2680		25	40	18
2800	2820		3180	3070	56	64	3000	5	124	244	2882		25	40	18
3000	3020		3405	3290	62	68	3210	5	132	257	3085		32	45	18

Dimensions of Weld Neck Flanges PN 16 EN 1092-1

DN	Pipe OD, A		Outside Diameter, D	Diameter of Bolt Circle, K	Dia of Bolt Hole, L	No. of bolt	Diameter of Raised Face, d	Height of Raised Face, f1	Flange thickness, C	Length of Flange, H	Neck Diameter, N		Wall thickness, S	Length of right end, H1	Radius of Corners, r
	Series I	Series II									Series I	Series II			
10	17.2	14	90	60	14	4	40	2	16	35	28		2	6	4
15	21.3	18	95	65	14	4	45	2	16	38	32		2	6	4
20	26.9	25	105	75	14	4	58	2	18	40	40		2.3	6	4
25	33.7	32	115	85	14	4	68	2	18	40	46		2.6	6	4
32	42.4	38	140	100	18	4	78	2	18	42	56		2.6	6	6
40	48.3	45	150	110	18	4	88	3	18	45	64		2.6	7	6
50	60.3	57	165	125	18	4	102	3	18	45	74		2.9	8	6
65	76.1	76	185	145	18	8	122	3	18	45	92		2.9	10	6
80	88.9	89	200	160	18	8	138	3	20	50	105		3.2	10	6
100	114.3	108	220	180	18	8	158	3	20	52	131		3.6	12	8
125	139.7	133	250	210	18	8	188	3	22	55	156		4	12	8
150	168.3	159	285	240	22	8	212	3	22	55	184		4.5	12	10
200	219.1	219	340	295	22	12	268	3	24	62	235		6.3	16	10
250	273	273	405	355	26	12	320	3	26	70	292		6.3	16	12
300	323.9	325	460	410	26	12	378	4	28	78	344		7.1	16	12
350	355.6	377	520	470	26	16	438	4	30	82	390	400	8	16	12
400	406.4	426	580	525	30	16	490	4	32	85	445	450	8	16	12
450	457	480	640	585	30	20	550	4	34	83	490	506	8	16	12
500	508	530	715	650	33	20	610	4	36	84	548	559	8	16	12
600	610	630	840	770	36	20	725	5	40	88	670	670	10	18	12
700	711	720	910	840	36	24	795	5	40	104	755	755	10	18	12
800	813	820	1025	950	39	24	900	5	62	108	855	855	12.5	20	12
900	914	920	1125	1050	39	28	1000	5	64	118	955	958	12.5	20	12
1000	1016	1020	1255	1170	42	28	1115	5	68	137	1058	1060	12.5	22	16
1200	1219	1220	1485	1390	48	32	1330	5	78	160	1262		14.2	30	16
1400	1422	1420	1685	1590	48	36	1530	5	84	177	1465		16	30	16
1600	1626	1620	1930	1820	56	40	1750	5	102	204	1668		17.5	35	16
1800	1829	1820	2130	2020	56	44	1950	5	110	218	1870		20	35	16
2000	2032	2020	2345	2230	62	48	2150	5	124	238	2072		22	40	16

Dimensions of Weld Neck Flanges PN 25 EN 1092-1

DN	Pipe OD, A		Outside Diamete, D	Diameter of Bolt Circle, K	Dia of Bolt Hole, L	No. of bolt	Diameter of Raised Face, d	Height of Raised Face, f1	Flange thickness, C	Length of Flange, H	Neck Diameter, N		Wall thickness, S	Length of right end, H1	Radius of Corners, r
	Series I	Series II									Series I	Series II			
10	17.2	14	90	60	14	4	40	2	16	35	28	2	6	4	
15	21.3	18	95	65	14	4	45	2	16	38	32	2	6	4	
20	26.9	25	105	75	14	4	58	2	18	40	40	2.3	6	4	
25	33.7	32	115	85	14	4	68	2	18	40	46	2.6	6	4	
32	42.4	38	140	100	18	4	78	2	18	42	56	2.6	6	6	
40	48.3	45	150	110	18	4	88	3	18	45	64	2.6	7	6	
50	60.3	57	165	125	18	4	102	3	20	48	75	2.9	8	6	
65	76.1	79	185	145	18	8	122	3	22	52	90	2.9	10	6	
80	88.9	89	200	160	18	8	138	3	24	58	105	3.2	12	8	
100	114.3	108	235	190	22	8	162	3	24	65	134	3.6	12	8	
125	139.7	133	270	220	26	8	188	3	26	68	162	4	12	8	
150	168.3	159	300	250	26	8	218	3	28	75	192	4.5	12	10	
200	219.1	219	360	310	26	12	278	3	30	80	244	6.3	16	10	
250	273	273	425	370	30	12	335	3	32	88	298	7.1	18	12	
300	323.9	325	485	430	30	16	395	4	34	92	352	8	18	12	
350	355.6	377	555	490	33	16	450	4	38	100	398	8	20	12	
400	406.4	426	620	550	36	16	505	4	40	110	452	464	8.8	20	12
450	457	480	670	600	36	20	555	4	46	110	500	514	8.8	20	12
500	508	530	730	660	36	20	615	4	48	125	558	570	10	20	12
600	610	630	845	770	39	20	720	5	48	125	660	670	11	20	12
700	711	720	960	875	42	24	820	5	50	129	760	766	14.2	20	12
800	813	820	1085	990	48	24	930	5	53	138	864	874	16	22	12
900	914	920	1185	1090	48	28	1030	5	57	148	968	974	17.5	24	12
1000	1016	1020	1320	1210	56	28	1140	5	63	160	1070	1074	20	24	16

Dimensions of Weld Neck Flanges PN 25 EN 1092-1

DN	Pipe OD, A		Outside Diamete, D	Diameter of Bolt Circle, K	Dia of Bolt Hole, L	No. of bolt	Diameter of Raised Face, d	Height of Raised Face, f1	Flange thickness, C	Length of Flange, H	Neck Diameter, N		Wall thickness, S	Length of right end, H1	Radius of Corners, r
	Series I	Series II									Series I	Series II			
10	17.2	14	90	60	14	4	40	2	16	35	28				
15	21.3	18	95	65	14	4	45	2	16	38	32	2	6	4	
20	26.9	25	105	75	14	4	58	2	18	40	40	2.3	6	4	
25	33.7	32	115	85	14	4	68	2	18	40	46	2.6	6	4	
32	42.4	38	140	100	18	4	78	2	18	42	56	2.6	6	6	
40	48.3	45	150	110	18	4	88	3	18	45	64	2.6	7	6	
50	60.3	57	165	125	18	4	102	3	20	48	75	2.9	8	6	
65	76.1	76	185	145	18	8	122	3	22	52	90	2.9	10	6	
80	88.9	89	200	160	18	8	138	3	24	58	105	3.2	12	8	
100	114.3	108	235	190	22	8	162	3	24	65	134	3.6	12	8	
125	139.7	133	270	220	26	8	188	3	26	68	162	4	12	8	
150	168.3	159	300	250	26	8	218	3	28	75	192	4.5	12	10	
200	219.1	219	375	320	30	12	285	3	34	88	244	6.3	16	10	
250	273	273	450	385	33	12	345	3	38	105	306	7.1	18	12	
300	323.9	325	515	450	33	16	410	4	42	115	362	8	18	12	
350	355.6	377	580	510	36	16	465	4	46	125	408	418	8.8	20	12
400	406.4	4126	660	585	39	16	535	4	50	135	462	480	11	20	12
450	457	480	685	610	39	20	560	4	57	135	500	530	12.5	20	12
500	508	530	755	670	42	20	615	4	57	140	562	580	14.2	20	12
600	610	630	890	795	48	20	735	5	72	150	666	686	16	20	12

Dimensions of Weld Neck Flanges PN 63 EN 1092-1

DN	Pipe OD, A		Outside Diamete, D	Diameter of Bolt Circle, K	Dia of Bolt Hole, L	No. of bolt	Diameter of Raised Face, d	Height of Raised Face, f1	Flange thickness, C	Length of Flange, H	Neck Diameter, N		Wall thickness, S	Length of right end, H1	Radius of Corners, r
	Series I	Series II									Series I	Series II			
10	17.2	14	100	70	14	4	40	2	20	45	32				
15	21.3	18	105	75	14	4	45	2	20	45	34	2	6	4	
20	26.9	25	130	90	18	4	58	2	22	48	42	2.6	8	4	
25	33.7	32	140	100	18	4	68	2	24	58	52	2.6	8	4	
32	42.4	38	155	110	22	4	78	2	24	60	62	2.9	8	6	
40	48.3	45	170	125	22	4	88	3	26	62	70	2.9	10	6	
50	60.3	57	180	135	22	4	102	3	26	62	82	4	10	6	
65	76.1	76	205	160	22	8	122	3	26	68	98	4	12	6	
80	88.9	89	215	170	22	8	138	3	28	72	112	4.5	12	8	
100	114.3	108	250	200	26	8	162	3	30	78	138	4.5	12	8	
125	139.7	133	295	240	30	8	188	3	34	88	168	5.6	12	8	
150	168.3	159	345	280	33	8	218	3	36	95	202	6.3	12	10	
200	219.1	219	415	345	36	12	285	3	42	110	256	7.1	16	10	
250	273	273	470	400	36	12	345	3	46	125	316	8.8	18	12	
300	323.9	325	530	460	36	16	410	4	52	140	372	11	18	12	
350	355.6	377	600	525	39	16	465	4	56	150	420	430	12.5	20	12
400	406.4	426	670	585	42	16	535	4	60	160	475	484	14.2	20	12

Dimensions of Weld Neck Flanges PN 63 EN 1092-1

DN	Pipe OD, A		Outside Diameter, D	Diameter of Bolt Circle, K	Dia of Bolt Hole, L	No. of bolt	Diameter of Raised Face, d	Height of Raised Face, f1	Flange thickness, C	Length of Flange, H	Neck Diameter, N		Wall thickness, S	Length of right end, H1	Radius of Corners, r
	Series I	Series II									Series I	Series II			
10	17.2	14	100	70	14	4	40	2	20	45	32	2	6	4	
15	21.3	18	105	75	14	4	45	2	20	45	34	3.2	6	4	
20	26.9	25	130	90	18	4	58	2	22	48	42	3.2	8	4	
25	33.7	32	140	100	18	4	68	2	24	58	52	3.6	8	4	
32	42.4	38	155	110	22	4	78	2	24	60	62	3.6	8	6	
40	48.3	45	170	125	22	4	88	3	26	62	70	3.6	10	6	
50	60.3	57	195	145	26	4	102	3	28	68	90	4	10	6	
65	76.1	76	220	170	26	8	122	3	30	76	108	4	12	6	
80	88.9	89	230	180	26	8	138	3	32	78	120	5	12	8	
100	114.3	108	265	210	30	8	162	3	36	90	150	5.6	12	8	
125	139.7	133	315	250	33	8	188	3	40	105	180	6.3	12	8	
150	168.3	159	355	290	33	12	218	3	44	115	210	8	12	10	
200	219.1	219	430	360	36	12	285	3	52	130	278	8.8	16	10	
250	273	273	505	430	39	12	345	3	60	157	340	10	18	12	
300	323.9	325	585	500	42	16	410	4	68	170	400	12.5	18	12	
350	355.6	377	655	560	48	16	465	4	74	189	460	14.2	20	12	

Dimensions of Weld Neck Flanges PN 160 EN 1092-1

DN	Pipe OD, A		Outside Diameter, D	Diameter of Bolt Circle, K	Dia of Bolt Hole, L	No. of bolt	Diameter of Raised Face, d	Height of Raised Face, f1	Flange thickness, C	Length of Flange, H	Neck Diameter, N		Wall thickness, S	Length of right end, H1	Radius of Corners, r
	Series I	Series II									Series I	Series II			
10	17.2	14	100	70	14	4	40	2	20	45	32	2	6	4	
15	21.3	18	105	75	14	4	45	2	20	45	34	2	6	4	
20	26.9	25	130	90	18	4	58	2	24	52	42	2.9	6	4	
25	33.7	32	140	100	18	4	68	2	24	58	52	2.9	8	4	
32	42.4	38	155	110	22	4	78	2	28	60	60	3.6	8	5	
40	48.3	45	170	125	22	4	88	3	28	64	70	3.6	10	6	
50	60.3	57	195	145	26	4	102	3	30	75	90	4	10	6	
65	76.1	76	220	170	26	8	122	3	34	82	108	5	12	6	
80	88.9	89	230	180	26	8	138	3	36	86	120	6.3	12	8	
100	114.3	108	265	210	30	8	162	3	40	100	150	8	12	8	
125	139.7	133	315	250	33	8	188	3	44	115	180	10	14	8	
150	168.3	159	355	290	33	12	218	3	50	128	210	12.5	14	10	
200	219.1	219	430	360	36	12	285	3	60	140	278	16	16	10	
250	273	273	515	430	42	12	345	3	68	155	340	20	18	12	
300	323.9	325	585	500	42	16	410	4	78	175	400	22.2	18	12	

Dimensions of Weld Neck Flanges PN 250 EN 1092-1

DN	Pipe OD, A		Outside Diameter, D	Diameter of Bolt Circle, K	Dia of Bolt Hole, L	No. of bolt	Diameter of Raised Face, d	Height of Raised Face, f1	Flange thickness, C	Length of Flange, H	Neck Diameter, N	Wall thickness, S	Length of right end, H1	Radius of Corners, r
	Series I	Series II												
10	17.2	14	125	85	18	4	40	2	24	58	44	2.6	6	4
15	21.3	18	130	90	18	4	45	2	26	60	48	2.6	6	4
20	26.9	25	135	95	18	4	58	2	28	62	54	3.2	8	4
25	33.7	32	150	105	22	4	68	2	28	65	60	3.6	8	4
32	42.4	38	165	120	22	4	78	2	32	70	72	4	8	4
40	48.3	45	185	135	26	4	88	3	34	80	84	5	10	6
50	60.3	57	200	150	26	8	102	3	38	85	95	6.3	10	6
65	76.1	76	230	180	26	8	122	3	42	95	124	8	12	6
80	101.6	101.6	255	200	30	8	138	3	46	102	136	11	12	8
100	127	127	300	235	33	8	162	3	54	120	164	14.2	14	8
125	152.4	152.4	340	275	33	12	188	3	60	140	200	16	16	8
150	177.8	177.8	390	320	36	12	218	3	68	160	240	17.5	18	10
200	244.5	244.5	485	400	42	12	285	3	82	190	305	25	25	10
250	298.5	298.5	585	490	48	16	345	3	100	215	385	32	30	12

Dimensions of Weld Neck Flanges PN 320 EN 1092-1

DN	Pipe OD, A	Outside Diamete, D	Diameter of Bolt Circle, K	Dia of Bolt Hole, L	No. of bolt	Diameter of Raised Face, d	Height of Raised Face, f1	Flange thickness, C	Length of Flange, H	Neck Diameter, N	Wall thickness, S	Length of right end, H1	Radius of Corners, r
10	17.2	125	85	18	4	40	2	24	58	44	2.6	6	4
15	21.3	130	90	18	4	45	2	26	60	48	3.2	6	4
20	26.9	145	100	22	4	58	2	30	70	58	4	8	4
25	33.7	160	115	22	4	68	2	34	78	68	5	8	4
32	42.4	175	130	26	4	78	2	36	83	80	5.6	8	4
40	48.3	195	145	26	4	88	3	38	88	92	6.3	10	6
50	60.3	210	160	26	8	102	3	42	100	106	8	10	6
65	88.9	255	200	30	8	122	3	51	120	138	11	12	6
80	101.6	275	220	30	8	138	3	55	130	156	12.5	14	8
100	133	335	265	36	8	162	3	65	145	186	16	16	8
125	168.3	380	310	36	12	188	3	75	175	230	20	20	8
150	193.7	425	350	39	12	218	3	84	195	265	25	25	10
200	244.5	525	440	42	16	285	3	103	235	345	30	30	10
250	323.9	640	540	52	16	345	3	125	300	428	40	40	12

Dimensions of Weld Neck Flanges PN 400 EN 1092-1

DN	Pipe OD, A	Outside Diamete, D	Diameter of Bolt Circle, K	Dia of Bolt Hole, L	No. of bolt	Diameter of Raised Face, d	Height of Raised Face, f1	Flange thickness, C	Length of Flange, H	Neck Diameter, N	Wall thickness, S	Length of right end, H1	Radius of Corners, r
10	17.2	125	85	18	4	40	2	28	65	48	3.6	8	4
15	26.9	145	100	22	4	45	2	30	68	56	5	8	4
20	33.7	160	115	22	4	58	2	34	80	70	6.3	10	4
25	42.4	180	130	26	4	68	2	38	90	82	7.1	10	4
32	48.3	200	145	26	4	78	2	43	100	94	8.8	12	6
40	60.3	220	165	30	4	88	3	48	110	106	10	12	6
50	76.1	235	180	30	8	102	3	52	120	120	12.5	15	6
65	101.6	290	225	33	8	122	3	64	135	158	16	18	6
80	114.3	305	240	33	8	138	3	68	150	174	17.5	20	8
100	139.7	370	295	39	8	162	3	80	175	216	22.2	25	8
125	193.7	415	340	39	12	188	3	92	200	258	30	30	8
150	219.1	475	390	42	12	218	3	105	225	302	35	35	10
200	273	585	490	48	16	285	3	130	280	388	40	40	10

Note: All dimensions are in mm. If you could not find the size, please contact Fluido sales team info@eathu.com.



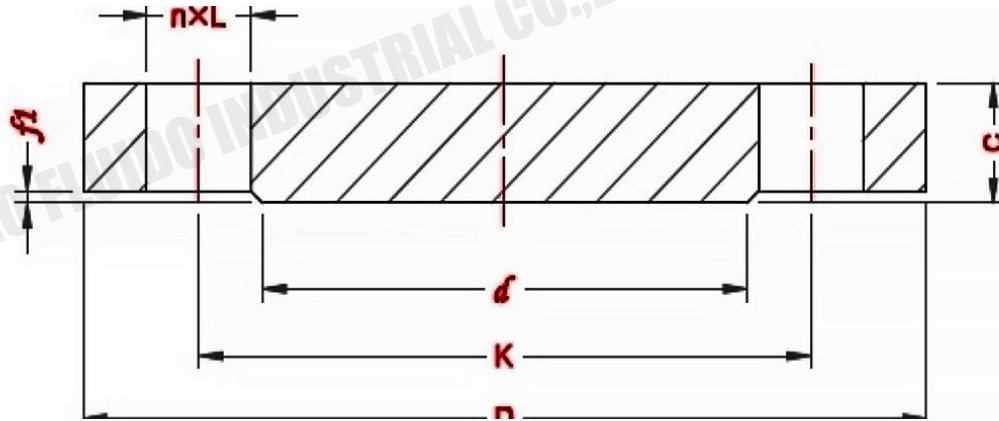

Dimensions of Blind Flanges PN 2.5 EN 1092-1

DN	Outside Diameter, D	Diameter of Bolt Circle, K	Dia of Bolt Hole, L	No. of bolt	Size of Bolt	Flange thickness, C	Diameter of Raised Face, d	Height of Raised Face, f1
10	75	50	11	4	M10	12	35	2
15	80	55	11	4	M10	12	40	2
20	90	65	11	4	M10	14	50	2
25	100	75	11	4	M10	14	60	2
32	120	90	14	4	M12	14	70	2
40	130	100	14	4	M12	14	80	3
50	140	110	14	4	M12	14	90	3
65	160	130	14	4	M12	14	110	3
80	190	150	18	4	M16	16	128	3
100	210	170	18	4	M16	16	148	3
125	240	200	18	8	M16	18	178	3
150	265	225	18	8	M16	18	202	3
200	320	280	18	8	M16	20	258	3
250	375	335	18	12	M16	22	312	3
300	440	395	22	12	M20	22	365	4
350	490	445	22	12	M20	22	415	4
400	540	495	22	16	M20	22	455	4
450	595	550	22	16	M20	24	520	4
500	645	600	22	20	M20	24	570	4
600	755	705	26	20	M24	30	670	5
700	860	810	26	24	M24	40	775	5
800	975	920	30	24	M27	44	880	5
900	1075	1020	30	24	M27	48	980	5
1000	1175	1120	30	28	M27	52	1080	5
1200	1375	1320	30	32	M27	50	1280	5
1400	1575	1520	30	36	M27	57	1480	5
1600	1790	1730	30	40	M27	64	1690	5
1800	1990	1930	30	44	M27	70	1890	5
2000	2190	2130	30	48	M27	78	2090	5

Dimensions of Blind Flanges PN 6 EN 1092-1

DN	Outside Diameter, D	Diameter of Bolt Circle, K	Dia of Bolt Hole, L	No. of bolt	Size of Bolt	Flange thickness, C	Diameter of Raised Face, d	Height of Raised Face, f1
10	75	50	11	4	M10	12	35	2
15	80	55	11	4	M10	12	40	2
20	90	65	11	4	M10	14	50	2
25	100	75	11	4	M10	14	60	2
32	120	90	14	4	M12	14	70	2
40	130	100	14	4	M12	14	80	3
50	140	110	14	4	M12	14	90	3
65	160	130	14	4	M12	14	110	3
80	190	150	18	4	M16	16	128	3
100	210	170	18	4	M16	16	148	3
125	240	200	18	8	M16	18	178	3
150	265	225	18	8	M16	18	202	3
200	320	280	18	8	M16	20	258	3
250	375	335	18	12	M16	22	312	3
300	440	395	22	12	M20	22	365	4
350	490	445	22	12	M20	22	415	4
400	540	495	22	16	M20	22	455	4
450	595	550	22	16	M20	24	520	4
500	645	600	22	20	M20	24	570	4
600	755	705	26	20	M24	30	670	5
700	860	810	26	24	M24	40	775	5
800	975	920	30	24	M27	44	880	5
900	1075	1020	30	24	M27	48	980	5
1000	1175	1120	30	28	M27	52	1080	5
1200	1405	1340	33	32	M30	60	1295	5
1400	1630	1560	36	36	M33	68	1510	5
1600	1830	1760	36	40	M33	76	1710	5
1800	2045	1970	39	44	M36	84	1920	5
2000	2265	2180	42	48	M39	92	2125	5

Dimensions of Blind Flanges PN 10 EN 1092-1

DN	Outside Diamete, D	Diameter of Bolt Circle, K	Dia of Bolt Hole, L	No. of bolt	Size of Bolt	Flange thickness, C	Diameter of Raised Face, d	Height of Raised Face, f1
10	90	60	14	4	M12	16	40	2
15	95	65	14	4	M12	16	45	2
20	105	75	14	4	M12	18	58	2
25	115	85	14	4	M12	18	68	2
32	140	100	18	4	M16	18	78	2
40	150	110	18	4	M16	18	88	3
50	165	125	18	4	M16	18	102	3
65	185	145	18	8	M16	18	122	3
80	200	160	18	8	M16	20	138	3
100	220	180	18	8	M16	20	158	3
125	250	210	18	8	M16	22	188	3
150	285	240	22	8	M20	22	212	3
200	340	295	22	8	M20	24	268	3
250	395	350	22	12	M20	26	320	3
300	445	400	22	12	M20	26	370	4
350	505	460	22	16	M20	26	430	4
400	565	515	26	16	M24	26	482	4
450	615	565	26	20	M24	28	532	4
500	670	620	26	20	M24	28	585	4
600	780	725	30	20	M27	34	685	5
700	895	840	30	24	M27	38	800	5
800	1015	950	33	24	M30	48	905	5
900	1115	1050	33	28	M30	50	1005	5
1000	1230	1160	36	28	M33	54	1110	5
1200	1455	1380	39	32	M36	66	1330	5
1400	1675	1590	42	36	M39	72	1535	5
1600	1915	1820	48	40	M45	82	1760	5
1800	2115	2020	48	44	M45	92	1960	5
2000	2325	2230	48	48	M45	100	2170	5

Dimensions of Blind Flanges PN 16 EN 1092-1

DN	Outside Diamete, D	Diameter of Bolt Circle, K	Dia of Bolt Hole, L	No. of bolt	Size of Bolt	Flange thickness, C	Diameter of Raised Face, d	Height of Raised Face, f1
10	90	60	14	4	M12	16	40	2
15	95	65	14	4	M12	16	45	2
20	105	75	14	4	M12	18	58	2
25	115	85	14	4	M12	18	68	2
32	140	100	18	4	M16	18	78	2
40	150	110	18	4	M16	18	88	3
50	165	125	18	4	M16	18	102	3
65	185	145	18	8	M16	18	122	3
80	200	160	18	8	M16	20	138	3
100	220	180	18	8	M16	20	158	3
125	250	210	18	8	M16	22	188	3
150	285	240	22	8	M20	22	212	3
200	340	295	22	8	M20	24	268	3
250	395	350	22	12	M20	26	320	3
300	445	400	22	12	M20	26	370	4
350	505	460	22	16	M20	26	430	4
400	565	515	26	16	M24	26	482	4
450	615	565	26	20	M24	28	532	4
500	670	620	26	20	M24	28	585	4
600	780	725	30	20	M27	34	685	5
700	895	840	30	24	M27	38	800	5
800	1015	950	33	24	M30	48	905	5
900	1115	1050	33	28	M30	50	1005	5
1000	1230	1160	36	28	M33	54	1110	5
1200	1455	1380	39	32	M36	66	1330	5
1400	1675	1590	42	36	M39	72	1535	5
1600	1915	1820	48	40	M45	82	1760	5
1800	2115	2020	48	44	M45	92	1960	5
2000	2325	2230	48	48	M45	100	2170	5

Dimensions of Blind Flanges PN 25 EN 1092-1

DN	Outside Diamete, D	Diameter of Bolt Circle, K	Dia of Bolt Hole, L	No. of bolt	Size of Bolt	Flange thickness, C	Diameter of Raised Face, d	Height of Raised Face, f1
10	90	60	14	4	M12	16	40	2
15	95	65	14	4	M12	16	45	2
20	105	75	14	4	M12	18	58	2
25	115	85	14	4	M12	18	68	2
32	140	100	18	4	M16	18	78	2
40	150	110	18	4	M16	18	88	3
50	165	125	18	4	M16	20	102	3
65	185	145	18	8	M16	22	122	3
80	200	160	18	8	M16	24	138	3
100	235	190	22	8	M20	24	162	3
125	270	220	26	8	M24	26	188	3
150	300	250	26	8	M24	28	218	3
200	360	310	26	12	M24	30	278	3
250	435	370	30	12	M27	32	335	3
300	485	430	30	16	M27	34	395	4
350	555	490	33	16	M30	38	450	4
400	620	550	36	16	M33	40	505	4
450	670	600	36	20	M33	50	555	4
500	730	660	36	20	M33	51	615	4
600	845	770	39	20	M36	66	720	5

Dimensions of Blind Flanges PN 40 EN 1092-1

DN	Outside Diamete, D	Diameter of Bolt Circle, K	Dia of Bolt Hole, L	No. of bolt	Size of Bolt	Flange thickness, C	Diameter of Raised Face, d	Height of Raised Face, f1
10	90	60	14	4	M12	16	40	2
15	95	65	14	4	M12	16	45	2
20	105	75	14	4	M12	18	58	2
25	115	85	14	4	M12	18	68	2
32	140	100	18	4	M16	18	78	2
40	150	110	18	4	M16	18	88	3
50	165	125	18	4	M16	20	102	3
65	185	145	18	8	M16	22	122	3
80	200	160	18	8	M16	24	138	3
100	235	190	22	8	M20	24	162	3
125	270	220	26	8	M24	26	188	3
150	300	250	26	8	M24	28	218	3
200	375	320	30	12	M27	36	285	3
250	450	385	33	12	M30	38	345	3
300	515	450	33	16	M30	42	410	4
350	580	510	36	16	M33	46	465	4
400	660	585	39	16	M36	50	535	4
450	685	610	39	20	M36	57	560	4
500	755	670	42	20	M39	57	615	4
600	890	795	48	20	M45	72	735	5

Dimensions of Blind Flanges PN 25 EN 1092-1

DN	Outside Diamete, D	Diameter of Bolt Circle, K	Dia of Bolt Hole, L	No. of bolt	Size of Bolt	Flange thickness, C	Diameter of Raised Face, d	Height of Raised Face, f1
10	90	60	14	4	M12	16	40	2
15	95	65	14	4	M12	16	45	2
20	105	75	14	4	M12	18	58	2
25	115	85	14	4	M12	18	68	2
32	140	100	18	4	M16	18	78	2
40	150	110	18	4	M16	18	88	3
50	165	125	18	4	M16	20	102	3
65	185	145	18	8	M16	22	122	3
80	200	160	18	8	M16	24	138	3
100	235	190	22	8	M20	24	162	3
125	270	220	26	8	M24	26	188	3
150	300	250	26	8	M24	28	218	3
200	360	310	26	12	M24	30	278	3
250	435	370	30	12	M27	32	335	3
300	485	430	30	16	M27	34	395	4
350	555	490	33	16	M30	38	450	4
400	620	550	36	16	M33	40	505	4
450	670	600	36	20	M33	50	555	4
500	730	660	36	20	M33	51	615	4
600	845	770	39	20	M36	66	720	5

Dimensions of Blind Flanges PN 40 EN 1092-1

DN	Outside Diamete, D	Diameter of Bolt Circle, K	Dia of Bolt Hole, L	No. of bolt	Size of Bolt	Flange thickness, C	Diameter of Raised Face, d	Height of Raised Face, f1
10	90	60	14	4	M12	16	40	2
15	95	65	14	4	M12	16	45	2
20	105	75	14	4	M12	18	58	2
25	115	85	14	4	M12	18	68	2
32	140	100	18	4	M16	18	78	2
40	150	110	18	4	M16	18	88	3
50	165	125	18	4	M16	20	102	3
65	185	145	18	8	M16	22	122	3
80	200	160	18	8	M16	24	138	3
100	235	190	22	8	M20	24	162	3
125	270	220	26	8	M24	26	188	3
150	300	250	26	8	M24	28	218	3
200	375	320	30	12	M27	36	285	3
250	450	385	33	12	M30	38	345	3
300	515	450	33	16	M30	42	410	4
350	580	510	36	16	M33	46	465	4
400	660	585	39	16	M36	50	535	4
450	685	610	39	20	M36	57	560	4
500	755	670	42	20	M39	57	615	4
600	890	795	48	20	M45	72	735	5

Dimensions of Blind Flanges PN 160 EN 1092-1

DN	Outside Diamete, D	Diameter of Bolt Circle, K	Dia of Bolt Hole, L	No. of bolt	Size of Bolt	Flange thickness, C	Diameter of Raised Face, d	Height of Raised Face, f1
10	100	70	14	4	M12	24	40	2
15	105	75	14	4	M12	26	45	2
20	130	90	18	4	M16	30	58	2
25	140	100	18	4	M16	32	68	2
32	155	110	22	4	M20	34	78	2
40	170	125	22	4	M20	36	88	3
50	195	145	26	4	M24	38	102	3
65	220	170	26	8	M24	42	122	3
80	230	180	26	8	M24	46	138	3
100	265	210	30	8	M27	52	162	3
125	315	250	33	8	M30	56	188	3
150	355	290	33	12	M30	62	218	3
200	430	360	36	12	M33	66	285	3
250	515	430	42	12	M39	76	345	3
300	585	500	42	16	M39	88	410	4



Note: All dimensions are in mm. If you could not find the size, please contact Fluido sales team info@eathu.com.

PL Flanges (EN1092.1)

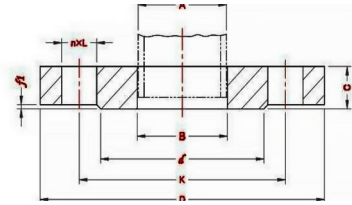

Dimensions of Plate Flanges PN 2.5 EN 1092-1

DN	Pipe OD, A		Outside Diamete, D	Diameter of Bolt Circle, K	Dia of Bolt Hole, L	No. of bolt	Size of Bolt	Flange thickness, C	Diameter of Raised Face, d	Height of Raised Face, f1	Bore diameter, B	
	Series I	Series II									Series I	Series II
10	17.2	14	75	50	11	4	M10	12	35	2	18	15
15	21.3	18	80	55	11	4	M10	12	40	2	22	19
20	26.9	25	90	65	11	4	M10	14	50	2	27.5	26
25	33.7	32	100	75	11	4	M10	14	60	2	34.5	33
32	42.4	38	120	90	14	4	M12	16	70	2	43.5	39
40	48.3	45	130	100	14	4	M12	16	80	3	49.5	46
50	60.3	57	140	110	14	4	M12	16	90	3	61.5	59
65	76.1	76	160	130	14	4	M12	16	110	3	77.5	78
80	88.9	89	190	150	18	4	M16	18	128	3	90.5	91
100	114.3	108	210	170	18	4	M16	18	148	3	116	110
125	139.7	133	240	200	18	8	M16	20	178	3	141.5	135
150	168.3	159	265	225	18	8	M16	20	202	3	170.5	161
200	219.1	219	320	280	18	8	M16	22	258	3	221.5	222
250	273	273	375	335	18	12	M16	24	312	3	276.5	276
300	323.9	325	440	395	22	12	M20	24	365	4	327.5	328
350	355.6	377	490	445	22	12	M20	26	415	4	359.5	380
400	406.4	426	540	495	22	16	M20	28	455	4	411	430
450	457	480	595	550	22	16	M20	30	520	4	462	484
500	508	530	645	600	22	20	M20	30	570	4	513.5	534
600	610	630	755	705	26	20	M24	32	670	5	616.5	634
700	711	720	860	810	26	24	M24	40	775	5	715	724
800	813	820	975	920	30	24	M27	44	880	5	817	824
900	914	920	1075	1020	30	24	M27	48	980	5	918	924
1000	1016	1020	1175	1120	30	28	M27	52	1080	5	1020	1024
1200	1219	1220	1375	1320	30	32	M27	60	1280	5	1223	1224

Dimensions of Plate Flanges PN 6 EN 1092-1

DN	Pipe OD, A		Outside Diamete, D	Diameter of Bolt Circle, K	Dia of Bolt Hole, L	No. of bolt	Size of Bolt	Flange thickness, C	Diameter of Raised Face, d	Height of Raised Face, f1	Bore diameter, B	
	Series I	Series II									Series I	Series II
10	17.2	14	75	50	11	4	M10	12	35	2	18	15
15	21.3	18	80	55	11	4	M10	12	40	2	22	19
20	26.9	25	90	65	11	4	M10	14	50	2	27.5	26
25	33.7	32	100	75	11	4	M10	14	60	2	34.5	33
32	42.4	38	120	90	14	4	M12	16	70	2	43.5	39
40	48.3	45	130	100	14	4	M12	16	80	3	49.5	46
50	60.3	57	140	110	14	4	M12	16	90	3	61.5	59
65	76.1	76	160	130	14	4	M12	16	110	3	77.5	78
80	88.9	89	190	150	18	4	M16	18	128	3	90.5	91
100	114.3	108	210	170	18	4	M16	18	148	3	116	110
125	139.7	133	240	200	18	8	M16	20	178	3	141.5	135
150	168.3	159	265	225	18	8	M16	20	202	3	170.5	161
200	219.1	219	320	280	18	8	M16	22	258	3	221.5	222
250	273	273	375	335	18	12	M16	24	312	3	276.5	276
300	323.9	325	440	395	22	12	M20	24	365	4	327.5	328
350	355.6	377	490	445	22	12	M20	26	415	4	359.5	380
400	406.4	426	540	495	22	16	M20	28	455	4	411	430
450	457	480	595	550	22	16	M20	30	520	4	462	484
500	508	530	645	600	22	20	M20	30	570	4	513.5	534
600	610	630	755	705	26	20	M24	32	670	5	616.5	634
700	711	720	860	810	26	24	M24	40	775	5	715	724
800	813	820	975	920	30	24	M27	44	880	5	817	824
900	914	920	1075	1020	30	24	M27	48	980	5	918	924
1000	1016	1020	1175	1120	30	28	M27	52	1080	5	1020	1024
1200	1219	1220	1405	1340	33	32	M30	60	1295	5	1223	1224
1400	1422	1420	1630	1560	36	36	M33	72	1510	5	1426	1424
1600	1626	1620	1830	1760	36	40	M33	80	1710	5	1630	1624
1800	1829	1820	2045	1970	39	44	M36	88	1920	5	1833	1824
2000	2032	2020	2265	2180	42	48	M39	96	2125	5	2036	2024

Dimensions of Plate Flanges PN 10 EN 1092-1

DN	Pipe OD, A		Outside Diameter, D	Diameter of Bolt Circle, K	Dia of Bolt Hole, L	No. of bolt	Size of Bolt	Flange thickness, C	Diameter of Raised Face, d	Height of Raised Face, f1	Bore diameter, B	
	Series I	Series II									Series I	Series II
10	17.2	14	90	60	14	4	M12	14	40	2	18	15
15	21.3	18	95	65	14	4	M12	14	45	2	22	19
20	26.9	25	105	75	14	4	M12	16	58	2	27.5	26
25	33.7	32	115	85	14	4	M12	16	68	2	34.5	33
32	42.4	38	140	100	18	4	M16	18	78	2	43.5	39
40	48.3	45	150	110	18	4	M16	18	88	3	49.5	46
50	60.3	57	165	125	18	4	M16	20	102	3	61.5	59
65	76.1	76	185	145	18	8	M16	20	122	3	77.5	78
80	88.9	89	200	160	18	8	M16	20	138	3	90.5	91
100	114.3	108	220	180	18	8	M16	22	158	3	116	110
125	139.7	133	250	210	18	8	M16	22	188	3	141.5	135
150	168.3	159	285	240	22	8	M20	24	212	3	170.5	161
200	219.1	219	340	295	22	8	M20	24	268	3	221.5	222
250	273	273	395	350	22	12	M20	26	320	3	276.5	276
300	323.9	325	445	400	22	12	M20	26	370	4	327.5	328
350	355.6	377	505	460	22	16	M20	30	430	4	359.5	380
400	406.4	426	565	515	26	16	M24	32	482	4	411	430
450	457	480	615	565	26	20	M24	36	532	4	462	484
500	508	530	670	620	26	20	M24	38	585	4	513.5	534
600	610	630	780	725	30	20	M27	42	685	5	616.5	634
700	711	720	895	840	30	24	M27	50	800	5	715	724
800	813	820	1015	950	33	24	M30	56	905	5	817	824
900	914	920	1115	1050	33	28	M30	62	1005	5	918	924
1000	1016	1020	1230	1160	36	28	M33	70	1110	5	1020	1024
1200	1219	1220	1455	1380	39	32	M36	83	1330	5	1223	1224
1400	1422	1420	1675	1590	42	36	M39	90	1535	5	1426	1424
1600	1626	1620	1915	1820	48	40	M45	100	1760	5	1630	1624
1800	1829	1820	2115	2020	48	44	M45	110	1960	5	1833	1824
2000	2032	2020	2325	2230	48	48	M45	120	2170	5	2036	2024

Dimensions of Plate Flanges PN 16 EN 1092-1

DN	Pipe OD, A		Outside Diameter, D	Diameter of Bolt Circle, K	Dia of Bolt Hole, L	No. of bolt	Size of Bolt	Flange thickness, C	Diameter of Raised Face, d	Height of Raised Face, f1	Bore diameter, B	
	Series I	Series II									Series I	Series II
10	17.2	14	90	60	14	4	M12	14	40	2	18	15
15	21.3	18	95	65	14	4	M12	14	45	2	22	19
20	26.9	25	105	75	14	4	M12	16	58	2	27.5	26
25	33.7	32	115	85	14	4	M12	16	68	2	34.5	33
32	42.4	38	140	100	18	4	M16	18	78	2	43.5	39
40	48.3	45	150	110	18	4	M16	18	88	3	49.5	46
50	60.3	57	165	125	18	4	M16	20	102	3	61.5	59
65	76.1	76	185	145	18	8	M16	20	122	3	77.5	78
80	88.9	89	200	160	18	8	M16	20	138	3	90.5	91
100	114.3	108	220	180	18	8	M16	22	158	3	116	110
125	139.7	133	250	210	18	8	M16	22	188	3	141.5	135
150	168.3	159	285	240	22	8	M20	24	212	3	170.5	161
200	219.1	219	340	295	22	12	M20	26	268	3	221.5	222
250	273	273	405	355	26	12	M24	29	320	3	276.5	276
300	323.9	325	460	410	26	12	M24	32	378	4	327.5	328
350	355.6	377	520	470	26	16	M24	35	438	4	359.5	380
400	406.4	426	580	525	30	16	M27	38	490	4	411	430
450	457	480	640	585	30	20	M27	42	550	4	462	484
500	508	530	715	650	33	20	M30	46	610	4	513.5	534
600	610	630	840	770	36	20	M33	55	725	5	616.5	634
700	711	720	910	840	36	24	M33	63	795	5	715	724
800	813	820	1025	950	39	24	M36	74	900	5	817	824
900	914	920	1125	1050	39	28	M36	82	1000	5	918	924
1000	1016	1020	1255	1170	42	28	M39	90	1115	5	1020	1024
1200	1219	1220	1485	1390	48	32	M45	95	1330	5	1223	1224
1400	1422	1420	1685	1590	48	36	M45	103	1530	5	1426	1424
1600	1626	1620	1930	1820	56	40	M52	115	1750	5	1630	1624
1800	1829	1820	2130	2020	56	44	M52	126	1950	5	1833	1824
2000	2032	2020	2345	2230	62	48	M56	138	2150	5	2036	2024

Dimensions of Plate Flanges PN 25 EN 1092-1

DN	Pipe OD, A		Outside Diamete, D	Diameter of Bolt Circle, K	Dia of Bolt Hole, L	No. of bolt	Size of Bolt	Flange thickness, C	Diameter of Raised Face, d	Height of Raised Face, f1	Bore diameter,B	
	Series I	Series II									Series I	Series II
10	10	14	90	60	14	4	M12	14	40	2	18	15
15	15	18	95	65	14	4	M12	14	45	2	22	19
20	20	25	105	75	14	4	M12	16	58	2	27.5	26
25	25	32	115	85	14	4	M12	16	68	2	34.5	33
32	32	38	140	100	18	4	M16	18	78	2	43.5	39
40	40	45	150	110	18	4	M16	18	88	3	49.5	46
50	50	57	165	125	18	4	M16	20	102	3	61.5	59
65	65	76	185	145	18	8	M16	22	122	3	77.5	78
80	80	89	200	160	18	8	M16	24	138	3	90.5	91
100	100	108	235	190	22	8	M20	26	162	3	116	110
125	125	133	270	220	26	8	M24	28	188	3	141.5	135
150	150	159	300	250	26	8	M24	30	218	3	170.5	161
200	200	219	360	310	26	12	M24	32	278	3	221.5	222
250	250	273	435	370	30	12	M27	35	335	3	276.5	276
300	300	325	485	430	30	16	M27	38	395	4	327.5	328
350	350	377	555	490	33	16	M30	42	450	4	359.5	380
400	400	426	620	550	36	16	M33	48	505	4	411	430
450	450	480	670	600	36	20	M33	54	555	4	462	484
500	500	530	730	660	36	20	M33	58	615	4	513.5	534
600	600	630	845	770	39	20	M36	68	720	5	616.5	634
700	700	720	960	875	42	24	M39	85	820	5	715	724
800	800	820	1085	990	48	24	M45	95	930	5	817	824

Dimensions of Plate Flanges PN 40 EN 1092-1

DN	Pipe OD, A		Outside Diamete, D	Diameter of Bolt Circle, K	Dia of Bolt Hole, L	No. of bolt	Size of Bolt	Flange thickness, C	Diameter of Raised Face, d	Height of Raised Face, f1	Bore diameter,B	
	Series I	Series II									Series I	Series II
10	17.2	14	90	60	14	4	M12	14	40	2	18	15
15	21.3	18	95	65	14	4	M12	14	45	2	22	19
20	26.9	25	105	75	14	4	M12	16	58	2	27.5	26
25	33.7	32	115	85	14	4	M12	16	68	2	34.5	33
32	42.4	38	140	100	18	4	M16	18	78	2	43.5	39
40	48.3	45	150	110	18	4	M16	18	88	3	49.5	46
50	60.3	57	165	125	18	4	M16	20	102	3	61.5	59
65	76.1	76	185	145	18	8	M16	22	122	3	77.5	78
80	88.9	89	200	160	18	8	M16	24	138	3	90.5	91
100	114.3	108	235	190	22	8	M20	26	162	3	116	110
125	139.7	133	270	220	26	8	M24	28	188	3	141.5	135
150	168.3	159	300	250	26	8	M24	30	218	3	170.5	161
200	219.1	219	375	320	30	12	M27	36	285	3	221.5	222
250	273	273	450	385	33	12	M30	42	345	3	276.5	276
300	323.9	325	515	450	33	16	M30	52	410	4	327.5	328
350	355.6	377	580	510	36	16	M33	58	465	4	359.5	380
400	406.4	426	660	585	39	16	M36	65	535	4	411	430
450	457	480	685	610	39	20	M36	66	560	4	462	484
500	508	530	755	670	42	20	M39	72	615	4	513.5	534
600	610	630	890	795	48	20	M45	84	735	5	616.5	634

Dimensions of Plate Flanges PN 63 EN 1092-1

DN	Pipe OD, A		Outside Diamete, D	Diameter of Bolt Circle, K	Dia of Bolt Hole, L	No. of bolt	Size of Bolt	Flange thickness, C	Diameter of Raised Face, d	Height of Raised Face, f1	Bore diameter, B	
	Series I	Series II									Series I	Series II
10	17.2	14	100	70	14	4	M12	20	40	2	18	15
15	21.3	18	105	75	14	4	M12	20	45	2	22	19
20	26.9	25	130	90	18	4	M16	22	58	2	27.5	26
25	33.7	32	140	100	18	4	M16	24	68	2	34.5	33
32	42.4	38	155	110	22	4	M20	24	78	2	43.5	39
40	48.3	45	170	125	22	4	M20	26	88	3	49.5	46
50	60.3	57	180	135	22	4	M20	26	102	3	61.5	59
65	76.1	76	205	160	22	8	M20	26	122	3	77.5	78
80	88.9	89	215	170	22	8	M20	30	138	3	90.5	91
100	114.3	108	250	200	26	8	M24	32	162	3	116	110
125	139.7	133	295	240	30	8	M27	34	188	3	141.5	135
150	168.3	159	345	280	33	8	M30	36	218	3	170.5	161
200	219.1	219	415	345	36	12	M33	48	285	3	221.5	222
250	273	273	470	400	36	12	M33	55	345	3	276.5	276
300	323.9	325	530	460	36	16	M33	65	410	4	327.5	328
350	355.6	377	600	525	39	16	M36	72	465	4	359.5	380
400	406.4	426	670	585	42	16	M39	80	535	4	411	430

Dimensions of Plate Flanges PN 100 EN 1092-1

DN	Pipe OD, A		Outside Diamete, D	Diameter of Bolt Circle, K	Dia of Bolt Hole, L	No. of bolt	Size of Bolt	Flange thickness, C	Diameter of Raised Face, d	Height of Raised Face, f1	Bore diameter, B	
	Series I	Series II									Series I	Series II
10	17.2	14	90	60	14	4	M12	14	40	2	18	15
15	21.3	18	95	65	14	4	M12	14	45	2	22	19
20	26.9	25	105	75	14	4	M12	16	58	2	27.5	26
25	33.7	32	115	85	14	4	M12	16	68	2	34.5	33
32	42.4	38	140	100	18	4	M16	18	78	2	43.5	39
40	48.3	45	150	110	18	4	M16	18	88	3	49.5	46
50	60.3	57	165	125	18	4	M16	20	102	3	61.5	59
65	76.1	76	185	145	18	8	M16	22	122	3	77.5	78
80	88.9	89	200	160	18	8	M16	24	138	3	90.5	91
100	114.3	108	235	190	22	8	M20	26	162	3	116	110
125	139.7	133	270	220	26	8	M24	28	188	3	141.5	135
150	168.3	159	300	250	26	8	M24	30	218	3	170.5	161
200	219.1	219	375	320	30	12	M27	36	285	3	221.5	222
250	273	273	450	385	33	12	M30	42	345	3	276.5	276
300	323.9	325	515	450	33	16	M30	52	410	4	327.5	328
350	355.6	377	580	510	36	16	M33	58	465	4	359.5	380
400	406.4	426	660	585	39	16	M36	65	535	4	411	430
450	457	480	685	610	39	20	M36	66	560	4	462	484
500	508	530	755	670	42	20	M39	72	615	4	513.5	534
600	610	630	890	795	48	20	M45	84	735	5	616.5	634

Th Flanges (EN1092.1)

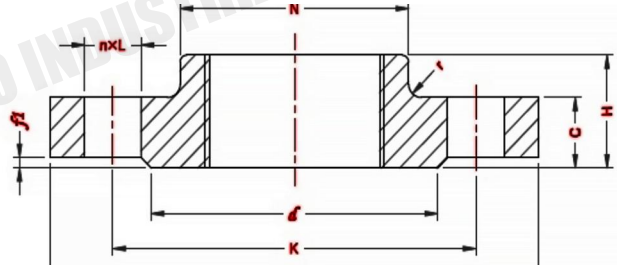

Dimensions of Threaded Flanges PN 6 EN 1092-1

DN	Pipe OD, A	Outside Diamete, D	Diameter of Bolt Circle, K	Dia of Bolt Hole, L	No. of bolt	Diameter of Raised Face, d	Height of Raised Face, f1	Flange thickness, C	Length of Flange, H	Neck Diameter, N	Radius of Corners, r
10	17.2	75	50	11	4	35	2	12	20	25	4
15	21.3	80	55	11	4	40	2	12	20	30	4
20	26.9	90	65	11	4	50	2	14	24	40	4
25	33.7	100	75	11	4	60	2	14	24	50	4
32	42.4	120	90	14	4	70	2	14	26	60	6
40	48.3	130	100	14	4	80	3	14	26	70	6
50	60.3	140	110	14	4	90	3	14	28	80	6
65	76.1	160	130	14	4	110	3	14	32	100	6
80	88.9	190	150	18	4	128	3	16	34	110	8
100	114.3	210	170	18	4	148	3	16	40	130	8
125	139.7	240	200	18	8	178	3	18	44	160	8
150	168.3	265	225	18	8	202	3	18	44	185	10
200	219.1	320	280	18	8	258	3	20	44	240	10
250	273	375	335	18	12	312	3	22	44	295	12
300	323.9	440	395	22	12	365	4	22	44	355	12

Dimensions of Threaded Flanges PN 10 EN 1092-1

DN	Pipe OD, A	Outside Diamete, D	Diameter of Bolt Circle, K	Dia of Bolt Hole, L	No. of bolt	Diameter of Raised Face, d	Height of Raised Face, f1	Flange thickness, C	Length of Flange, H	Neck Diameter, N	Radius of Corners, r
10	17.2	90	60	14	4	40	2	16	22	30	4
15	21.3	95	65	14	4	45	2	16	22	35	4
20	26.9	105	75	14	4	58	2	18	26	45	4
25	33.7	115	85	14	4	68	2	18	28	52	4
32	42.4	140	100	18	4	78	2	18	30	60	6
40	48.3	150	110	18	4	88	3	18	32	70	6
50	60.3	165	125	18	4	102	3	18	28	84	6
65	76.1	185	145	18	8	122	3	18	32	104	6
80	88.9	200	160	18	8	138	3	20	34	118	6
100	114.3	220	180	18	8	158	3	20	40	140	8
125	139.7	250	210	18	8	188	3	22	44	168	8
150	168.3	285	240	22	8	212	3	22	44	195	10
200	219.1	340	295	22	8	268	3	24	44	246	10
250	273	395	350	22	12	320	3	26	46	298	12
300	323.9	445	400	22	12	370	4	26	46	350	12
350	355.6	505	460	22	16	430	4	26	53	400	12
400	406.4	565	515	26	16	482	4	26	57	456	12
450	457	615	565	26	20	532	4	28	63	502	12
500	508	670	620	26	20	585	4	28	67	559	12
600	610	780	725	30	20	685	5	30	75	658	12

Dimensions of Threaded Flanges PN 16 EN 1092-1

DN	Pipe OD, A	Outside Diamete, D	Diameter of Bolt Circle, K	Dia of Bolt Hole, L	No. of bolt	Diameter of Raised Face, d	Height of Raised Face, f1	Flange thickness, C	Length of Flange, H	Neck Diameter , N	Radius of Corners, r
10	17.2	90	60	14	4	40	2	16	22	30	4
15	21.3	95	65	14	4	45	2	16	22	35	4
20	26.9	105	75	14	4	58	2	18	26	45	4
25	33.7	115	85	14	4	68	2	18	28	52	4
32	42.4	140	100	18	4	78	2	18	30	60	6
40	48.3	150	110	18	4	88	3	18	32	70	6
50	60.3	165	125	18	4	102	3	18	28	84	6
65	76.1	185	145	18	8	122	3	18	32	104	6
80	88.9	200	160	18	8	138	3	20	34	118	6
100	114.3	220	180	18	8	158	3	20	40	140	8
125	139.7	250	210	18	8	188	3	22	44	168	8
150	168.3	285	240	22	8	212	3	22	44	195	10
200	219.1	340	295	22	12	268	3	24	44	246	10
250	273	405	355	26	12	320	3	26	46	398	12
300	323.9	460	410	26	12	378	4	28	46	350	12
350	355.6	520	470	26	16	438	4	30	67	400	12
400	406.4	580	525	30	16	490	4	32	63	456	12
450	457	640	585	30	20	550	4	34	68	502	12
500	508	715	650	33	20	610	4	36	73	559	12
600	610	840	770	36	20	725	5	40	83	658	12

Dimensions of Threaded Flanges PN 25 EN 1092-1

DN	Pipe OD, A	Outside Diamete, D	Diameter of Bolt Circle, K	Dia of Bolt Hole, L	No. of bolt	Diameter of Raised Face, d	Height of Raised Face, f1	Flange thickness, C	Length of Flange, H	Neck Diameter , N	Radius of Corners, r
10	17.2	90	60	14	4	40	2	16	22	30	4
15	21.3	95	65	14	4	45	2	16	22	35	4
20	26.9	105	75	14	4	58	2	18	26	45	4
25	33.7	115	85	14	4	68	2	18	28	52	4
32	42.4	140	100	18	4	78	2	18	30	60	6
40	48.3	150	110	18	4	88	3	18	32	70	6
50	60.3	165	125	18	4	102	3	20	34	84	6
65	76.1	185	145	18	8	122	3	22	38	104	6
80	88.9	200	160	18	8	138	3	24	40	118	8
100	114.3	235	190	22	8	162	3	24	44	145	8
125	139.7	270	220	26	8	188	3	26	48	170	8
150	168.3	300	250	26	8	218	3	28	52	200	10
200	219.1	360	310	26	12	278	3	30	52	256	10
250	273	425	370	30	12	335	3	32	60	310	12
300	323.9	485	430	30	16	395	4	34	67	364	12
350	355.6	555	490	33	16	450	4	38	72	418	12
400	406.4	620	550	36	16	505	4	40	78	472	12
450	457	670	600	36	20	555	4	46	84	520	12
500	508	730	660	36	20	615	4	48	90	580	12
600	610	845	770	39	20	720	5	48	100	684	12

Dimensions of Threaded Flanges PN 40 EN 1092-1

DN	Pipe OD, A	Outside Diamete, D	Diameter of Bolt Circle, K	Dia of Bolt Hole, L	No. of bolt	Diameter of Raised Face, d	Height of Raised Face, f1	Flange thickness, C	Length of Flange, H	Neck Diameter , N	Radius of Corners, r
10	17.2	90	60	14	4	40	2	16	22	30	4
15	21.3	95	65	14	4	45	2	16	22	35	4
20	26.9	105	75	14	4	58	2	18	26	45	4
25	33.7	115	85	14	4	68	2	18	28	52	4
32	42.4	140	100	18	4	78	2	18	30	60	6
40	48.3	150	110	18	4	88	3	18	32	70	6
50	60.3	165	125	18	4	102	3	20	34	84	6
65	76.1	185	145	18	8	122	3	22	38	104	6
80	88.9	200	160	18	8	138	3	24	40	118	8
100	114.3	235	190	22	8	162	3	24	44	145	8
125	139.7	270	220	26	8	188	3	26	48	170	8
150	168.3	300	250	26	8	218	3	28	52	200	10
200	219.1	375	320	30	12	285	3	34	52	260	10
250	273	450	385	33	12	345	3	38	60	312	12
300	323.9	515	450	33	16	410	4	42	67	380	12
350	355.6	580	510	36	16	465	4	46	72	424	12
400	406.4	660	585	39	16	535	4	50	78	478	12
450	457	685	610	39	20	560	4	57	84	522	12
500	608	755	670	42	20	615	4	57	90	576	12
600	610	890	795	48	20	735	5	72	100	686	12

Dimensions of Threaded Flanges PN 63 EN 1092-1

DN	Pipe OD, A	Outside Diamete, D	Diameter of Bolt Circle, K	Dia of Bolt Hole, L	No. of bolt	Diameter of Raised Face, d	Height of Raised Face, f1	Flange thickness, C	Length of Flange, H	Neck Diameter , N	Radius of Corners, r
10	17.2	100	70	14	4	40	2	20	28	40	4
15	21.3	105	75	14	4	45	2	20	28	43	4
20	26.9	130	90	18	4	58	2	20	30	52	4
25	33.7	140	100	18	4	68	2	24	32	60	4
32	42.4	155	110	22	4	78	2	24	32	68	6
40	48.3	170	125	22	4	88	3	26	34	80	6
50	60.3	180	135	22	4	102	3	26	36	90	6
65	76.1	205	160	22	8	122	3	26	40	112	6
80	88.9	215	170	22	8	138	3	28	44	125	8
100	114.3	250	200	26	8	162	3	30	52	152	8
125	139.7	295	240	30	8	188	3	34	56	185	8
160	168.3	345	280	33	8	218	3	36	60	215	10

Dimensions of Threaded Flanges PN 100 EN 1092-1

DN	Pipe OD, A	Outside Diamete, D	Diameter of Bolt Circle, K	Dia of Bolt Hole, L	No. of bolt	Diameter of Raised Face, d	Height of Raised Face, f1	Flange thickness, C	Length of Flange, H	Neck Diameter , N	Radius of Corners, r
10	17.2	100	70	14	4	40	2	20	28	40	4
15	21.3	105	75	14	4	45	2	20	28	43	4
20	26.9	130	90	18	4	58	2	20	30	52	4
25	33.7	140	100	18	4	68	2	24	32	60	4
32	42.4	155	110	22	4	78	2	24	32	68	6
40	48.3	170	125	22	4	88	3	26	34	80	6
50	60.3	195	145	26	4	102	3	28	36	95	6
65	76.1	220	170	26	8	122	3	30	40	118	6
80	88.9	230	180	26	8	138	3	32	44	130	8
100	114.3	265	210	30	8	162	3	36	52	158	8
125	139.7	315	250	33	8	188	3	40	56	188	8
150	168.3	355	290	33	12	218	3	44	60	225	10